

To:

- 1. Transmission Capital Partners
17th Floor
88 Wood Street
London
EC2V 7DA**

- 2. All interested parties**

NOTICE UNDER SECTION 8A(3) OF THE ELECTRICITY ACT 1989

The Gas and Electricity Markets Authority (the Authority) hereby gives notice pursuant to section 8A(3) of the Electricity Act 1989 (the Act) as follows:

1. An application for an electricity transmission licence (the **Licence**) to be granted under section 6(1)(b) of the Act has been received by the Authority from TC Beatrice OFTO Limited (the **Applicant** and the **Potential Licensee**) (company number: 12374249).
2. The Applicant is taking part in the competitive tender being conducted by the Authority to determine to whom the Licence is to be granted in respect of the Beatrice transmission system extending from point A to points B1 and B2 (as defined below) together with all associated cables, transformers, switchgear and connections, and all other plant or equipment making up or supporting the said transmission system with the benefit, subject to the applicable conditions therein, of all wayleaves and/or servitude rights relating thereto, where:

A is the onshore substation connection point: Latitude 57°31.441'N, Longitude 2°57.306'W

B is the offshore connection points:

B1 Offshore substation (**OTM1**): Latitude 58°15.004'N, Longitude 2°52.834'W

B2 Offshore substation (**OTM2**): Latitude 58°15.411'N, Longitude 2°53.750'W

3. If the Applicant resolves to the Authority's satisfaction the matters specified in regulation 21(4) of the Electricity (Competitive Tenders for Offshore Transmission Licences) Regulations 2015, and if the Authority determines to grant the Licence to the Potential Licensee, then the Authority proposes to modify Standard Conditions E12 (Not used) and E13 (System Operator – Transmission Owner Code) of the Licence.
4. The proposed modifications involve:
 - (a) omitting Standard Condition E12 (Not Used), and adding to the Licence Amended Standard Conditions:

E12 - A1 (Definitions and Interpretation)
E12 - A2 (Market Rate Revenue Adjustment)
E12 - A3 (Post Tender Revenue Adjustment)
E12 - B1 (Transmission System Area)
E12 - B2 (Activities Restrictions)
E12 - C1 (Conduct of the Transmission Business)
E12 - C2 (Separation and Independence of the Transmission Business)
E12 - C3 (Restriction on use of certain information)
E12 - C4 (Appointment of Compliance Officer)
E12 - D1 (Offshore Regulatory Reporting)
E12 - D2 (Equity Transaction Reporting Requirement)
E12 - J1 (Not Used)
E12 - J2 (Restriction of Transmission Revenue: Revenue from Transmission Owner Services)
E12 - J3 (Restriction of Transmission Revenue: Allowed Pass-through Items)

E12 - J4 (Restriction of Transmission Revenue: Annual Revenue Adjustments)
E12 - J5 (Restriction of Transmission Revenue: Adjustments)
E12 - J6 (Provision of Information to the System Operator)
E12 - J7 (Duration of the Revenue Restriction Provisions)
E12 - J8 (Allowances in respect of Security Costs)
E12 - J9 (Basis of Transmission Owner Charges)
E12 - J10 (Excluded Services)
E12 - J11 (The Network Innovation Competition)
E12 - J12 (Sulphur Hexafluoride Reporting Requirements)

and,

(b) modifying Standard Condition E13.

5. The effect of these modifications is:

- i. for Amended Standard Condition E12 - A1, to set out the relevant definitions and interpretations that relate to the proposed Amended Standard Conditions;
- ii. for Amended Standard Condition E12 - A2, to set out the process for adjusting the base transmission revenue of the Potential Licensee to account for the difference in market rates between those assumed in the tender revenue stream and those determined on the date of financial close;
- iii. for Amended Standard Condition E12 - A3, to define the process for determining the post tender revenue adjustment;
- iv. for Amended Standard Conditions E12 - B1 and E12 - B2, to set out the boundaries and location of the transmission system and the activities that the Potential Licensee is restricted from taking part in;
- v. for Amended Standard Conditions E12 - C1 to E12 - C4, to set out provisions on business separation between the Potential Licensee and any associated business;
- vi. for Amended Standard Condition E12 - D1, to set out the requirements on the Potential Licensee to provide information to the Authority for each relevant year;
- vii. for Amended Standard Condition E12 - D2, to set out the requirement on the Potential Licensee to provide information to the Authority on equity transactions;
- viii. for Amended Standard Conditions E12 - J1 to E12 - J10, to set out incentives and obligations on the Potential Licensee with regards to:
 1. revenue entitlement from transmission owner services (E12 - J2);
 2. revenue adjustments to reflect allowed pass-through items (E12 - J3);

3. annual revenue adjustments (such as the transmission system availability incentive and incremental capacity incentive) (E12 - J4);
 4. reporting to the Authority in respect of regulated transmission revenue exceeding allowed transmission owner revenue (E12 - J5);
 5. provision of information to the System Operator (E12 - J6);
 6. duration of the revenue restriction provisions (E12 - J7);
 7. allowances in respect of security costs (E12 - J8);
 8. basis of transmission owner charges (E12 - J9); and
 9. excluded services (E12 - J10);
- ix. for Amended Standard Condition E12 - J11, to establish arrangements known as the Network Innovation Competition (the **NIC**) which will enable the Potential Licensee to compete for funding for eligible NIC projects;
 - x. for Amended Standard Condition E12 - J12, to set out how the Potential Licensee is expected to report to the Authority its annual sulphur hexafluoride emissions; and
 - xi. for Standard Condition E13, add two new paragraphs (paragraphs 5 and 6), which set out that, where the Authority directs, any reference to a "Special Condition" in the System Operator – Transmission Owner Code (the **STC**) or the STC Framework Agreement shall be read as "Amended Standard Condition" in relation to this Licence.
- 6.** The reasons why the Authority proposes to make these modifications are set out in various documents published by or on behalf of the Authority including:
- (a) <https://www.ofgem.gov.uk/publications-and-updates/decision-modifications-offshore-transmission-licences>, November 2020;
 - (b) <https://www.ofgem.gov.uk/publications-and-updates/decision-modifications-future-offshore-transmission-licences>, November 2020;
 - (c) <https://www.ofgem.gov.uk/publications-and-updates/statutory-consultation-proposed-modifications-offshore-transmission-licences>, August 2020;
 - (d) <https://www.ofgem.gov.uk/publications-and-updates/modification-amended-standard-condition-e12-j11-network-innovation-competition-offshore-transmission-owners%E2%80%99-licences>, February 2015;
 - (e) <https://www.ofgem.gov.uk/publications-and-updates/decision-under-section-11a-1-b-electricity-act-1989-modify-offshore-electricity-transmission-licenses-so-introduce-amended-standard-condition-e12-d2-equity-transaction-reporting-requirement>, October 2014;
 - (f) <https://www.ofgem.gov.uk/publications-and-updates/offshore-transmission-notice-under-section-11a1a-electricity-act-1989-network-innovation>

- [competition?docid=4&refer=Networks/offtrans/pdc/cdr/2013](#), January 2013;
- (g) <https://www.ofgem.gov.uk/publications-and-updates/decision-letter-changes-availability-incentive-version-1.1-offshore-transmission-owner-of-to-licence?docid=30&refer=Networks/offtrans/pdc/cdr/Cons2011>, July 2011;
- (h) <https://www.ofgem.gov.uk/publications-and-updates/offshore-electricity-transmission-final-statement-competitive-tender-process?docid=85&refer=Networks/offtrans/pdc/cdr/cons2009>, June 2009;
- (i) <https://www.ofgem.gov.uk/publications-and-updates/overview-great-britain%E2%80%99s-offshore-electricity-transmission-regulatory-regime-joint-decc-ofgem-statement?docid=83&refer=Networks/offtrans/pdc/cdr/cons2009>, June 2009;
- (j) <https://www.ofgem.gov.uk/publications-and-updates/offshore-electricity-transmission-%E2%80%93-joint-ofgemdecc-regulatory-policy-update?docid=81&refer=Networks/offtrans/pdc/cdr/cons2008November>, November 2008

In summary, the reasons are, in relation to:

- (a) Standard Condition E12: to omit from the Licence that Standard Condition which is "Not Used" and instead to add to the Licence Amended Standard Conditions E12 - A1 to E12 - J12 which provide for the revenue entitlement, performance incentives, business separation requirements, regulatory reporting and other requirements and obligations on the Potential Licensee; and
- (b) Standard Condition E13: to ensure that, if a direction under paragraph 5 of Standard Condition E13 is issued, a reference to a Special Condition A1 to J12 in the STC or the STC Framework Agreement shall be read in relation to the Licence so as to be consistent with the relevant reference to any of Amended Standard Conditions E12 - A1 to E12 - J12 of the Licence.
- 7.** The specific reasons for adding Amended Standard Conditions E12 - A1 to E12 - J12 are to:
- (a) establish the process for determining the Post Tender Revenue Adjustment (PTRA_t). The PTRA_t is the adjustment (whether upwards or downwards) of the Base Transmission Revenue (BR_t) (E12 - A3);
- (b) ensure that the Potential Licensee's role as a transmission owner is clearly defined by setting out in the Licence the boundaries and location of the transmission system and the activities in which the Potential Licensee is restricted from taking part (E12 - B1 and E12 - B2);
- (c) ensure that no affiliated party of the Potential Licensee can obtain an unfair commercial advantage in other markets, by requiring the Potential Licensee to have in place the appropriate systems, processes, and information restrictions. This is done by setting out the requirements for business separation between the Potential Licensee and any associated business (E12 - C1 to E12 - C4);
- (d) protect the interests of consumers by enabling the Authority to monitor the revenue of the transmission business (including any under and over collection

of revenue) by requiring the Potential Licensee to provide appropriate information to the Authority, thus allowing the Authority to monitor whether the correct revenues are being collected by the Potential Licensee (E12 - D1, E12 - D2 and E12 - J5);

- (e) secure that the Potential Licensee is able to finance its activities by providing for the Potential Licensee to be remunerated for:
 - i. providing transmission owner services, by setting out how it should calculate its revenue entitlement (E12 - J2, E12 - J3 and E12 - J4). The Tender Revenue Stream stated in Amended Standard Condition E12 - J2 is based on the tender revenue stream bid by the Applicant at the Invitation to Tender (**ITT**) stage of the tender process, which has been updated to reflect further information available to the Applicant since the date of the ITT submission, including the draft final transfer value for the Beatrice transmission system; and
 - ii. providing excluded services (E12 - J10);
- (f) ensure that the transmission assets are operated in a manner that contributes to security of supply and facilitates the transmission of renewable electricity, by incentivising the Potential Licensee to maximise the availability of the transmission assets (E12 - J4);
- (g) protect the interests of consumers by ensuring that mechanisms are provided in the Licence to enable adjustments to be made to the revenue entitlement of the Potential Licensee for diverse matters including cost pass-through items (E12 - J3), market rates changes (E12 - A2) and for costs incurred by the Potential Licensee for providing transmission owner services during a security period following a direction issued by the Secretary of State under section 34(4) of the Act (E12 - J8);
- (h) ensure the Potential Licensee provides relevant information to the System Operator so that the System Operator can collect the correct amount of revenue for the Potential Licensee through the Transmission Network Use of System charges (E12 - J6);
- (i) enable the Authority, where requested by the Potential Licensee, to remove part or all of the revenue restrictions that are applied to the Potential Licensee (E12 - J7);
- (j) ensure that there is a statement in a form approved by the Authority setting out the basis upon which the Potential Licensee will make transmission owner and excluded services charges (E12 - J9 and E12 - J10); and
- (k) enable the Potential Licensee to take part in the Network Innovation Competition (E12 - J11); and
- (l) ensure the Potential Licensee appropriately reports the annual levels of sulphur hexafluoride emissions to the Authority (E12 - J12 and E12 - D1).

8. The Authority has added a contingent event revenue adjustment mechanism (the **CEA mechanism**) to Amended Standard Condition E12 - J3. The CEA mechanism is a bespoke term in the Licence providing for revenue adjustments for discrete pass-through items in relation to the Beatrice transmission system. In summary, when determined by the Authority, it provides for an adjustment to the Potential Licensee's

revenue entitlement should costs and/or expenses arise in the event that the Potential Licensee has been required:

- (a) by the Secretary of State to increase the size of its security in respect of its decommissioning programme to account for the payment of VAT; and
- (b) by the National Electricity Transmission System Operator to undertake works, and has undertaken those works, to reduce the impact or likelihood of sub synchronous voltage oscillations on the National Electricity Transmission System; and
- (c) to undertake works to replace all or part of a transformer radiator and/or any associated equipment due to a radiator fault that is directly caused by a specified root cause or remedial works and only within a defined up to two-year period.

9. The Authority has also included a new provision in Amended Standard Condition E12 - J4 (Restriction of Transmission Revenue: Annual Revenue Adjustments) so that a Transmission Service Reduction is excluded from the calculation of the Potential Licensee's availability incentive for circumstances where it has been required:

- (a) by the National Electricity Transmission System Operator to take action to reduce the impact or likelihood of sub synchronous voltage oscillations on the National Electricity Transmission System; and/or
- (b) to undertake works to replace all or part of a transformer radiator and/or any associated equipment due to a radiator fault that is directly caused by a specified root cause or remedial works and only within a defined up to two-year period.

10. The proposed modifications, which are set out in an annex to this notice, and the documents referred to in this notice, are available on the website www.ofgem.gov.uk.

11. Any representations or objections to the proposed modifications must be made via email only due to the ongoing COVID restrictions on or before midnight at the end of 7 July 2021 to: John Sinclair and Sean Payne at offshorelicensing@ofgem.gov.uk.

.....

Rebecca Barnett
Deputy Director
Systems and Networks

Duly authorised on behalf of the
Gas and Electricity Markets Authority

9 June 2021

Amended Standard Condition E12–A1: Definitions and Interpretation

1. This condition defines particular words and expressions that are used in the Amended Standard Conditions.
2. However not all defined words and expressions used in the Amended Standard Conditions are defined here. Some words and expressions used in the Amended Standard Conditions are defined in the Standard Conditions.
3. Unless the context otherwise requires, words and expressions used in the Standard Conditions of this licence shall bear the same meaning in these Amended Standard Conditions.
4. Where a term is used in these Amended Standard Conditions and is also used in Section E of the Standard Conditions of electricity transmission licences then, unless the context otherwise requires, it shall have the same meaning in these Amended Standard Conditions as is ascribed to that term in Section E of the Standard Conditions.
5. Any reference in these Amended Standard Conditions to:
 - (a) a provision thereof;
 - (b) a provision of the Standard Conditions of electricity transmission licences;
 - (c) a provision of the Standard Conditions of electricity supply licences;
 - (d) a provision of the Standard Conditions of electricity distribution licences;
 - (e) a provision of the Standard Conditions of electricity generation licences;
 - (f) a provision of the Standard Conditions of electricity interconnector licences;

shall, if these or the Standard Conditions in question come to be modified, be construed, so far as the context permits as a reference to the corresponding provision of these or the Standard Conditions in question as modified.

Definitions in alphabetical order

6. In these Amended Standard Conditions unless the context otherwise requires:

"Allowed Pass-through Items"	means the items referred to in paragraph 2 of Amended Standard Condition E12–J3 (Restriction of Transmission Revenue: Allowed Pass-through Items).
"Allowed Security Cost"	means any cost allowed by the Authority (upon receipt of such information, including a certificate from the Auditors, as the Authority may request) as being a cost which is directly attributable to any action taken or omitted to be taken by the licensee in its capacity as holder of the licence for the

	purpose of complying with directions issued by the Secretary of State under section 34(4) of the Act.
"Allowed Transmission Owner Revenue" or "OFTO _t "	means in the Commencement Relevant Year and every subsequent Relevant Year the revenue calculated in accordance with the formula set out in paragraph 4 of Amended Standard Condition E12–J2 (Restriction of Transmission Revenue: Revenue from Transmission Owner Services).
"Asset Transfer"	means the transfer to the licensee of the transmission system to which this licence relates as set out in Annex B to Amended Standard Condition E12–B1 (Transmission System Area).
"Associated Business"	means an Affiliate, Related Undertaking, or business unit of the Transmission Business or the Ultimate Controller of the Transmission Business.
"Average Specified Rate" or "I _t "	means the average value of the Bank of England's Official Bank Rate (or any other bank as the Authority may from time to time direct) during the period in respect of which the calculation in question falls to be made.
"Base Date"	means the date at which the transmission asset prices are based. For the purposes of this licence it shall be 30 September 2019.
"Base Transmission Revenue" or "BR _t "	means the revenue calculated in accordance with the formula set out in paragraph 4 of Amended Standard Condition E12–J2 (Restriction of Transmission Revenue: Revenue from Transmission Owner Services).
"Charge Restriction Conditions"	means any condition (including, without limitation, any revenue restriction condition) of this licence which places a monetary limitation on the revenue which may be recovered by the licensee during a given period.
"Closing Relevant Year"	means the Relevant Year, commencing 1 April 2044 being no earlier than 23 years after the Commencement Relevant Year.
"Commencement Relevant Year"	means the Relevant Year, commencing 1 April 2021, in which this condition comes into force. In this Relevant Year, t=1.

"Competent Authority"	means the Secretary of State, the Authority, the Compliance Officer, the Stock Exchange, the Panel on Takeovers and Mergers, or any local or national agency, regulatory body, authority, department, inspectorate, minister (including Scottish and Welsh Ministers), ministry, official or public or statutory person (whether autonomous or not) of, or of the government of, the United Kingdom, the United States of America or the European Union.
"Confidential Information"	for the purposes of Amended Standard Condition E12–C3 (Restriction on use of certain information) means any information relating to or deriving from the management or operation of the transmission business.
"Crown Estate Lease"	means any lease, licence, or agreement between the licensee and the Crown Estate relating to the use of Crown Estate property to enable the transmission of electricity over the Licensee’s Transmission System.
"Directly Attributable Costs"	for the purposes of Amended Standard Condition E12–J11 (Network Innovation Competition) has the meaning given to that term in paragraph 10 of that condition subject to any further explanation or elaboration that might be set out in the NIC Governance Document.
"Disallowed Expenditure"	for the purposes of Amended Standard Condition E12–J11 (The Network Innovation Competition) has the meaning given to that term in paragraph 8 of that condition subject to any further explanation or elaboration that might be set out in the NIC Governance Document.
"Disapplication Date"	means the date on which the licensee proposes that the Charge Restriction Conditions should be disappplied in whole or in part as specified in a Disapplication Request under Amended Standard Condition E12–J7 (Duration of the Revenue Restriction Provisions).
"Disapplication Notice"	means a notice to terminate the application of the Charge Restriction Conditions (in whole or in part) for the purposes of and in accordance with Amended Standard Condition E12–J7 (Duration of the Revenue

	Restriction Provisions).
"Disapplication Request"	means a request to disapply the Charge Restriction Conditions (in whole or in part) for the purposes of and in accordance with Amended Standard Condition E12-J7 (Duration of the Revenue Restriction Provisions).
"Distributions"	for the purposes of Amended Standard Condition E12-J3 (Restriction of Transmission Revenue: Allowed Pass-through Items) means whether in cash or any kind, any: <ul style="list-style-type: none"> (a) Dividend or other distribution in respect of share capital; (b) Reduction of capital, redemption or purchase of shares or any other reorganisation or variation to share capital; (c) Payments under the Internal Debt financing agreements (whether of principal, interest, breakage costs or otherwise).
"Electricity Arbitration Association"	means the unincorporated members' club of that name formed inter alia to promote the efficient and economic operation of the procedure for the resolution of disputes within the electricity supply industry by means of arbitration or otherwise in accordance with its arbitration rules.
"Eligible NIC Project"	subject to any further explanation or elaboration that might be set out in the NIC Governance Document, means a project undertaken by the licensee or any other Transmission Licensee that appears to the Authority to satisfy such requirements of the NIC Governance Document as are necessary to enable the project to be funded under the NIC Funding Mechanism.
"Equity IRR"	has the meaning given to that term in paragraph 41 of Amended Standard Condition E12-J3 (Restriction of Transmission Revenue: Allowed Pass-through Items).
"event"	means any unscheduled or unplanned occurrence on, or relating to, a Transmission System including, without limitation, faults,

	incidents, breakdowns and adverse weather conditions.
"Exceptional Event"	means an event or circumstance that is beyond the reasonable control of the licensee and which results in or causes a Transmission Service Reduction and includes (without limitation) an act of God, an act of the public enemy, war declared or undeclared, threat of war, terrorist act, blockade, revolution, riot, insurrection, civil commotion, public demonstration, sabotage, act of vandalism, fire (not related to weather), governmental restraint, Act of Parliament, any other legislation, bye law, or directive (not being any order, regulation or direction under section 32, 33, 34 and 35 of the Act) or decision of a Court of Competent Authority or any other body having jurisdiction over the activities of the licensee provided that lack of funds shall not be interpreted as a cause beyond the reasonable control of the licensee. For the avoidance of doubt, weather conditions which are reasonably expected to occur at the location of the event or circumstance are not considered to be beyond the reasonable control of the licensee.
"Excluded Services"	means those services provided by the licensee as part of its Transmission Business which in accordance with the principles set out in paragraph 7 of Amended Standard Condition E12–J10 (Excluded Services), are to be treated as Excluded Services.
"Exempt Refinancing"	has the meaning given to that term in paragraph 46 of Amended Standard Condition E12–J3 (Restriction of Transmission Revenue: Allowed Pass-through Items).
"External Debt"	for the purposes of Amended Standard Condition E12–J3 (Restriction of Transmission Revenue: Allowed Pass-through Items) means debt of the licensee provided directly or indirectly by a party who is not a shareholder of the licensee.
"External Transmission Activities"	means any business of the licensee or any Affiliate or Related Undertaking of the licensee comprising or ancillary to the

	<p>maintenance, repair or operation in an emergency of any electricity Distribution System or any part of the National Electricity Transmission System other than the Licensee's Transmission System.</p>
"Financial Close Protocol"	<p>means the process and/or timescales agreed with the Authority whereby the licensee effects the funding for Asset Transfer.</p>
"Financial Distress"	<p>describes a situation where the licensee cannot access the financial resources required to discharge its obligations under this licence.</p>
"Financial Model"	<p>for the purposes of Amended Standard Condition E12–J3 (Restriction of Transmission Revenue: Allowed Pass-through Items) means the financial model used to set the Market Rate Revenue Adjustment (MRA_t) as part of the Financial Close Protocol.</p>
"Financial Security"	<p>means a deposit of money, a performance bond or bank guarantee, an insurance policy or a letter of credit.</p>
"Force Majeure"	<p>means any event or circumstance which is beyond the reasonable control of the licensee including act of God, strike, lockout or other industrial disturbance, act of the public enemy, war declared or undeclared, threat of war, terrorist act, blockade, revolution, riot, insurrection, civil commotion, public demonstration, sabotage, act of vandalism, lightning, fire, storm, flood, earthquake, accumulation of snow or ice, lack of water arising from weather or environmental problems, explosion, government restraint, Act of Parliament, other legislation, bye law and Directive (not being any order, regulation or direction under sections 32, 33, 34 and 35 of the Act) and provided, for the avoidance of doubt, that weather conditions which are reasonably to be expected at the location of the event or circumstance are also excluded as not being beyond the reasonable control of the licensee.</p>
"Funding Return"	<p>for the purposes of Amended Standard Condition E12–J11(The Network Innovation Competition) has the meaning given to that</p>

	term in paragraph 6 of that condition subject to any further explanation or elaboration that might be set out in the NIC Governance Document.
"Funding Return Mechanism"	for the purposes of Amended Standard Condition E12–J11(The Network Innovation Competition) has the meaning given to that term in paragraph 5 of that condition subject to any further explanation or elaboration that might be set out in the NIC Governance Document.
"Good Industry Practice"	means in relation to any undertaking and any circumstances, the exercise of that degree of skill, diligence, prudence and foresight which would reasonably and ordinarily be expected from a skilled and experienced operator engaged in the same type of undertaking under the same or similar circumstances.
"Halted Project Revenues"	for the purposes of Amended Standard Condition E12–J11(The Network Innovation Competition) has the meaning given to that term in paragraph 7 of that condition subject to any further explanation or elaboration that might be set out in the NIC Governance Document.
"Incentive Period y"	means the twelve month period commencing 1 January of Relevant Year t-2 and ending 31 December of Relevant Year t-1 (inclusive).
"Income Adjusting Event"	has the meaning set out in paragraph 15 of Amended Standard Condition E12–J3 (Restriction of Transmission Revenue: Allowed Pass-through Items).
"Incremental Capacity Incentive Adjustment term" or "ICA _t "	means the revenue adjustment calculated in accordance with the formula set out in Part C of Amended Standard Condition E12–J4 (Restriction of Transmission Revenue: Annual Revenue Adjustments).
"Internal Debt"	for the purposes of Amended Standard Condition E12–J3 (Restriction of Transmission Revenue: Allowed Pass-through Items) means debt of the licensee which is not External Debt.
"Market Rate Revenue Adjustment" or	means the value set out in any direction issued pursuant to Amended Standard

"MRA _t "	Condition E12–A2 (Market Rate Revenue Adjustment), otherwise it shall take the value zero.
"Market Rates"	means the following: <ul style="list-style-type: none"> (a) interest rates; (b) retail prices index swap rates; (c) gilt rates; (d) index linked gilt rates; and (e) bond spreads.
"Network Rates"	means: <ul style="list-style-type: none"> (a) in England and Wales, the rates payable by the licensee in respect of hereditaments on the Central Rating Lists (England and Wales) compiled under section 52 of the Local Government Finance Act 1988 and hereditaments on the Local Rating Lists compiled under sections 41 and 41A of the Local Government Finance Act 1988; and (b) in Scotland, the rates payable by the licensee in respect of any land and heritages on the Valuation Rolls compiled under the Local Government (Scotland) Act 1975 and the Local Government etc. (Scotland) Act 1994.
"Network Rates Revaluation"	means the exercise undertaken, typically at five yearly intervals, to reset the Network Rates payable by the licensee.
"NIC Funding"	for the purposes of Amended Standard Condition E12–J11 (The Network Innovation Competition) has the meaning given to that term in paragraph 16 of that condition subject to any further explanation or elaboration that might be set out in the NIC Governance Document.
"NIC Funding Mechanism"	subject to any further explanation or elaboration that might be set out in the NIC Governance Document, refers to the arrangements (pursuant to Special Condition 3I of its Transmission Licence) for the recovery by the System Operator through its Transmission Network Charges of the

	amount of total authorised NIC Funding in any Relevant Year and the apportionment of that amount between the System Operator, the licensee, and other Transmission Licensees.
"NIC Governance Document"	means the document issued by the Authority under Part E of Amended Standard Condition E12–J11 (The Network Innovation Competition), subject to the requirements of Part F of Amended Standard Condition E12–J11, relating generally to the NIC and including matters relating to the operation of the NIC Funding Mechanism.
"Non-Chargeable Outage Change"	means a change to the Outage Plan notified by the System Operator which the licensee and the System Operator agree.
"Normal Capability Limits"	means the technical limits that would normally apply to the provision of its Transmission Services in accordance with the STC as at the date this condition comes into force.
"Original Change"	means a change to the Outage Plan requested by the licensee.
"Outage"	means a planned temporary reduction in the extent to which Transmission Services are provided by a Transmission Owner.
"Outage Change"	means a change notified to the licensee by the System Operator on or after week 49 of the calendar year to the Outage Plan, as updated from time to time in accordance with the STC as at the date this condition comes into force, other than: <ul style="list-style-type: none"> (a) the Original Change, and (b) such changes notified to the licensee by the System Operator which: <ul style="list-style-type: none"> (i) the licensee and the System Operator agree are necessary in order to give effect to the Original Change, or (ii) where there is a failure to agree, the Authority determines are necessary in

order to give effect to the Original Change; and

- (c) without prejudice to subparagraphs (a) and (b) above, a Non-Chargeable Outage Change.

"Outage Plan"	means the plan for the placement of Outages for each Financial Year developed and maintained by System Operator in accordance with the STC as at the date this condition comes into force.
"Post Tender Revenue Adjustment" or "PTRA _t "	means the value set out in any direction issued pursuant to Amended Standard Condition E12–A3 (Post Tender Revenue Adjustment), otherwise it shall take the value zero.
"Project Direction"	means a direction issued by the Authority pursuant to the NIC Governance Document setting out the terms to be followed in relation to an Eligible NIC Project as a condition of its funding under the NIC Funding Mechanism.
"Proposed Refinancing Gain"	has the meaning given to that term in paragraph 37(b) of Amended Standard Condition E12–J3 (Restriction of Transmission Revenue: Allowed Pass-through Items).
"Proposed Refinancing Gain Share"	has the meaning given to that term in paragraph 37(c) of Amended Standard Condition E12–J3 (Restriction of Transmission Revenue: Allowed Pass-through Items).
"Qualifying Refinancing"	has the meaning given to that term in paragraph 35 of Amended Standard Condition E12–J3 (Restriction of Transmission Revenue: Allowed Pass-through Items).
"Relevant Equity Transaction"	means any transaction which: <ul style="list-style-type: none">(a) involves the issue, sale (or otherwise transfer) or buy back of shares in the licensee; and/or(b) results in a change in an ultimate controller of the licensee.
"Refinancing"	has the meaning given to that term in paragraph 34 of Amended Standard

	Condition E12–J3 (Restriction of Transmission Revenue: Allowed Pass-through Items).
"Refinancing Gain"	means the value of the gain realised by the licensee from a Qualifying Refinancing as determined by the Authority in accordance with paragraph 44 of Amended Standard Condition E12–J3 (Restriction of Transmission Revenue: Allowed Pass-through Items).
"Refinancing Gain Share" or "RFG _t "	means the value of the pass-through revenue adjustment term, which is determined by the Authority in accordance with paragraph 44 of Amended Standard Condition E12–J3 (Restriction of Transmission Revenue: Allowed Pass-through Items).
"Regulated Transmission Revenue" or "AR _t "	means the revenue (measured on an accruals basis) derived from the provision of Transmission Owner Services (including to any separate business, other than the Transmission Business) in the Relevant Year, after deduction of value added tax (if any) and any other taxes based directly on the amounts so derived.
"Relevant Person"	for the purposes of Amended Standard Condition E12–J3 (Restriction of Transmission Revenue: Allowed Pass-through Items) means a shareholder of the licensee, an Affiliate of the licensee or a shareholder of an Affiliate of the licensee.
"Relevant Year"	means a year beginning on 1 April of each calendar year and ending on 31 March of the following calendar year.
"Relevant Year t"	means that Relevant Year for the purposes of which any calculation falls to be made.
"Relevant Year t-1"	means the Relevant Year immediately preceding Relevant Year t and similar expressions shall be construed accordingly.
"Retail Prices Index Number"	means the monthly index number of retail prices as identified by series CHAW by the Office of National Statistics where the index on 13 January 1987 = 100
"Returned Project Revenues"	has the meaning given to that term in Part C of Amended Standard Condition E12–J11 (The Network Innovation Competition).

"Returned Royalty Income"	for the purposes of Amended Standard Condition E12–J11(The Network Innovation Competition) has the meaning given to that term in paragraph 9 of that condition subject to any further explanation or elaboration that might be set out in the NIC Governance Document.
"Security Period"	means a period commencing on the date on which any direction issued by the Secretary of State under section 34(4) of the Act enters effect and terminating on the date (being not earlier than the date such direction, as varied, is revoked or expires) as the Authority, after consultation with such persons (including without limitation, licence holders liable to be principally affected) as it shall consider appropriate, may with the consent of the Secretary of State by notice to all licence holders determine after having regard to the views of such persons.
"Services Capability Specification"	means the specification of Transmission Owner Services provided and maintained in accordance with the STC.
"Services Reduction"	means the licensee’s Transmission Services are not, other than by reason of an Outage, physically capable of being provided or are not capable, for immediate safety reasons or pursuant to environmental obligations, of being provided.
"Services Reduction Risk "	means a risk, materially beyond the normal level of risk, of an imminent Services Reduction.
"Service Restoration Proposal"	means a Transmission Owner’s proposal, in accordance with the STC as at the date this condition comes into force, in reasonable but not excessive detail for, as appropriate: <ul style="list-style-type: none"> (a) any interim works or other actions which are able to be undertaken by such Transmission Owner to minimise the effect of the Services Reduction or Services Reduction Risk and including, where relevant, any revised operational capability limits that would apply during the

	<p>period of such Services Reduction or Services Reduction Risk;</p> <p>(b) restoring the Transmission Services such that they are provided in accordance with their Services Capability Specification (and to their Normal Capability Limits); and</p> <p>(c) otherwise removing, mitigating or dealing with a Services Reduction Risk,</p> <p>including, in the case of sub-paragraphs (b) and (c), where necessary and appropriate, by proposing to amend the content of its Services Capability Specification (including any Normal Capability Limits).</p>
"Target Availability"	means the target availability in percentage terms and is set at 98 per cent.
"Tender Regulations"	means the Electricity (Competitive Tenders for Offshore Transmission Licences) Regulations 2015.
"Tender Relevant Year"	means the Relevant Year in which the date that the tender exercise to which the grant of this licence relates was concluded, falls.
"Tender Revenue Stream" or "TRS _t "	means the value set out in paragraph 4 of Amended Standard Condition E12–J2 (Restriction of Transmission Revenue: Revenue from Transmission Owner Services).
"Transmission Entry Capacity"	means the figure specified as such for a connection site in a transmission owner construction agreement in accordance with the STC as at the date this condition comes into force.
"Transmission Network Charges"	means charges levied by the System Operator in respect of the provision of Transmission Network Services.
"Transmission Owner Services"	means all services provided as part of the Transmission Business other than Excluded Services.
"Transmission Service Reduction"	means a reduction in Transmission Services from the parameters and levels set out in the Services Capability Specification as a result of an Outage or Services Reduction.
"Transmission System Area"	means the area specified in Annex A of Amended Standard Condition E12–B1

"Transmission System Availability Incentive" or "AI _t "	(Transmission System Area). means the revenue adjustment calculated in accordance with the formula set out in Part A of Amended Standard Condition E12–J4 (Restriction of Transmission Revenue: Annual Revenue Adjustments).
“Uninsurable”	means that the Authority determines either that: <ul style="list-style-type: none"> <li data-bbox="847 533 1414 808">(a) Insurance is not available to the licensee in respect of all or part of its Transmission Assets in the Worldwide Offshore Transmission Asset Insurance Market with reputable insurers of good standing in respect of a Risk; or <li data-bbox="847 813 1414 1084">(b) the Insurance premium payable for insuring that Risk is at such a level that the Risk is deemed as not being insurable in the Worldwide Offshore Transmission Asset Insurance Market with reputable insurers of good standing.
	Where:
	<ul style="list-style-type: none"> <li data-bbox="847 1137 1414 1375">(c) a "Risk" means the physical loss or damage requiring replacement or rectification of Transmission Assets, which is caused by a Latent Defect resulting from material workmanship design plan or specification; <li data-bbox="847 1379 1414 1809">(d) "Insurance" means the indemnity which would normally be covered by an Operational All Risk insurance policy with a LEG 3/06 exclusion, or equivalent, which includes indemnity for the full cost of replacement or rectification of the Offshore Transmission Assets (but not improvement) rendered necessary by damage which is the consequence of a Latent Defect; <li data-bbox="847 1814 1414 2004">(e) a "Latent Defect" means a flaw in Offshore Transmission Assets, which: <ul style="list-style-type: none"> <li data-bbox="983 1928 1337 2004">(i) is an actual defect in material workmanship

design plan or specification, not the damage resulting from the defect; and

- (ii) existed but which would not have been apparent to an efficient licensee in the position of the licensee at the time the Offshore Transmission Assets were transferred to it;
- (f) "LEG 3/06" means the London Engineering Group Unique Market Reference for the Model "Improvement" Defects Wording;
- (g) "Worldwide Offshore Transmission Asset Insurance Market" means all insurers who, after an exhaustive search, would reasonably be understood by an efficient licensee, in the position of the licensee, to be participating in the business of insuring offshore transmission assets (to be determined by the Authority); and
- (h) "Offshore Transmission Asset/s" means the transmission system to which the licensee's Offshore Transmission Owner Licence relates as set out in Annex B to Amended Standard Condition E12-B1 (Transmission System Area) in the licensee's Offshore Transmission Owner Licence.

Amended Standard Condition E12–A2: Market Rate Revenue Adjustment

1. The purpose of this condition is to establish the process for determining the Market Rate Revenue Adjustment (MRA_t). The MRA_t is the adjustment (whether upwards or downwards) of the Base Transmission Revenue (BR_t) of the licensee as a consequence of the difference between:
 - (a) Market Rates assumed in the Tender Revenue Stream (TRS_t) and determined for the Post Tender Revenue Adjustment ($PTRA_t$); and
 - (b) Market Rates determined on the date of the Authority's direction pursuant to paragraph 6 of this condition.
2. For the purpose of paragraph 1(a), the Market Rates determined for the $PTRA_t$ shall be the Market Rates assumed in the TRS_t .
3. The licensee shall use reasonable endeavours to have in place on the date this condition comes into force, an Authority approved market rate revenue adjustment methodology statement as is necessary to facilitate the achievement of the market rate revenue adjustment objectives set out in paragraph 4.
4. For the purpose of paragraph 3 of this condition, the market rate revenue adjustment objectives are:
 - (a) that compliance with the market rate revenue adjustment methodology ensures that the MRA_t shall only reflect changes in Market Rates;
 - (b) that compliance with the market rate revenue adjustment methodology ensures that the MRA_t shall take account of the difference between Market Rates described in paragraph 1(a) and paragraph 1(b); and
 - (c) that compliance with the market rate revenue adjustment methodology ensures that the MRA_t may be effected in a manner which is compatible with the Financial Close Protocol.
5. For the purposes of paragraph 1, the MRA_t shall be calculated in accordance with the Authority approved market rate revenue adjustment methodology statement.
6. As soon as reasonably practicable after this condition comes into force (and in any case, no later than the date of Asset Transfer) the Authority may direct in writing the value of the MRA_t .

Amended Standard Condition E12–A3: Post Tender Revenue Adjustment

1. The purpose of this condition is to establish the process for determining the Post Tender Revenue Adjustment (PTRA_t). The PTRA_t is the adjustment (whether upwards or downwards) of the Base Transmission Revenue (BR_t) of the licensee as a consequence of the difference between:
 - (a) the Authority’s estimate of the costs associated with developing and constructing the transmission system to which this licence relates; and
 - (b) the Authority’s assessment, once the transmission system is available for use for the transmission of electricity, of the costs associated with developing and constructing the transmission system to which this licence relates.
2. For the purposes of paragraph 1, the value of the PTRA_t shall account for:
 - (a) the difference between:
 - (i) the Authority’s estimate assumed in the Tender Revenue Stream (TRS_t) of the costs associated with developing and constructing the transmission system to which this licence relates; and
 - (ii) the Authority’s assessment, once the transmission system is available for use for the transmission of electricity, of the costs associated with developing and constructing the transmission system to which this licence relates;where (i) and (ii) have been calculated in accordance with the Tender Regulations.
 - (b) the economic and efficient costs incurred by the licensee as a consequence of the difference between the estimate and assessment of the costs described in sub-paragraphs 2(a)(i) and (ii) above.
3. The licensee shall use reasonable endeavours to have in place on the date this condition comes into force, an Authority approved post tender revenue adjustment methodology statement as is necessary to facilitate the achievement of the post tender revenue adjustment objectives set out in paragraph 4.
4. For the purpose of paragraph 3 of this condition, the post tender revenue adjustment objectives are:
 - (a) that compliance with the post tender revenue adjustment methodology ensures that the PTRA_t shall take account of the difference between the Authority’s estimate and the Authority’s assessment described in sub-paragraphs 2(a) (i) and (ii); and
 - (b) that compliance with the post tender revenue adjustment methodology ensures that the PTRA_t may be effected in a manner which is compatible with the Financial Close Protocol.
5. For the purposes of paragraph 1, the PTRA_t shall be calculated in accordance with the Authority approved post tender revenue adjustment methodology statement.
6. As soon as reasonably practicable after this condition comes into force (and in any case, no later than the date of Asset Transfer) the Authority may direct in writing, the value of the PTRA_t.

Amended Standard Condition E12–B1: Transmission System Area

1. This licence is granted for the "Beatrice transmission system" within the Specified Area (stated in Schedule 1 (Specified Area) of this licence) and more particularly defined in paragraph 2.
2. In this condition, the "Beatrice transmission system" means the Offshore Transmission System extending from point A to point B (defined below) together with all associated cables, transformers, switchgear and connections, and all other plant or equipment making up or supporting the said transmission system with the benefit, subject to the applicable conditions therein, of all wayleaves and/or servitude rights relating thereto where:
 - A is the onshore connection point: Latitude 57° 31.441'N,
Longitude 2° 57.306'W
 - B is the offshore connection point:
 - B1 offshore substation 1 (OTM1) Latitude 58° 15.004'N,
Longitude 2° 52.834'W
 - B2 offshore substation 2 (OTM2) Latitude 58° 15.411'N,
Longitude 2° 53.750'W

In this condition, the Transmission System Area is the geographic area set out in Annex A to this condition. The connection points of the Licensee's Transmission System are also defined by the circuit diagram in Annex B to this condition.

ANNEX A TO AMENDED STANDARD CONDITION E12-B1 (TRANSMISSION SYSTEM AREA)

The Transmission System Area is the marked area set out below.

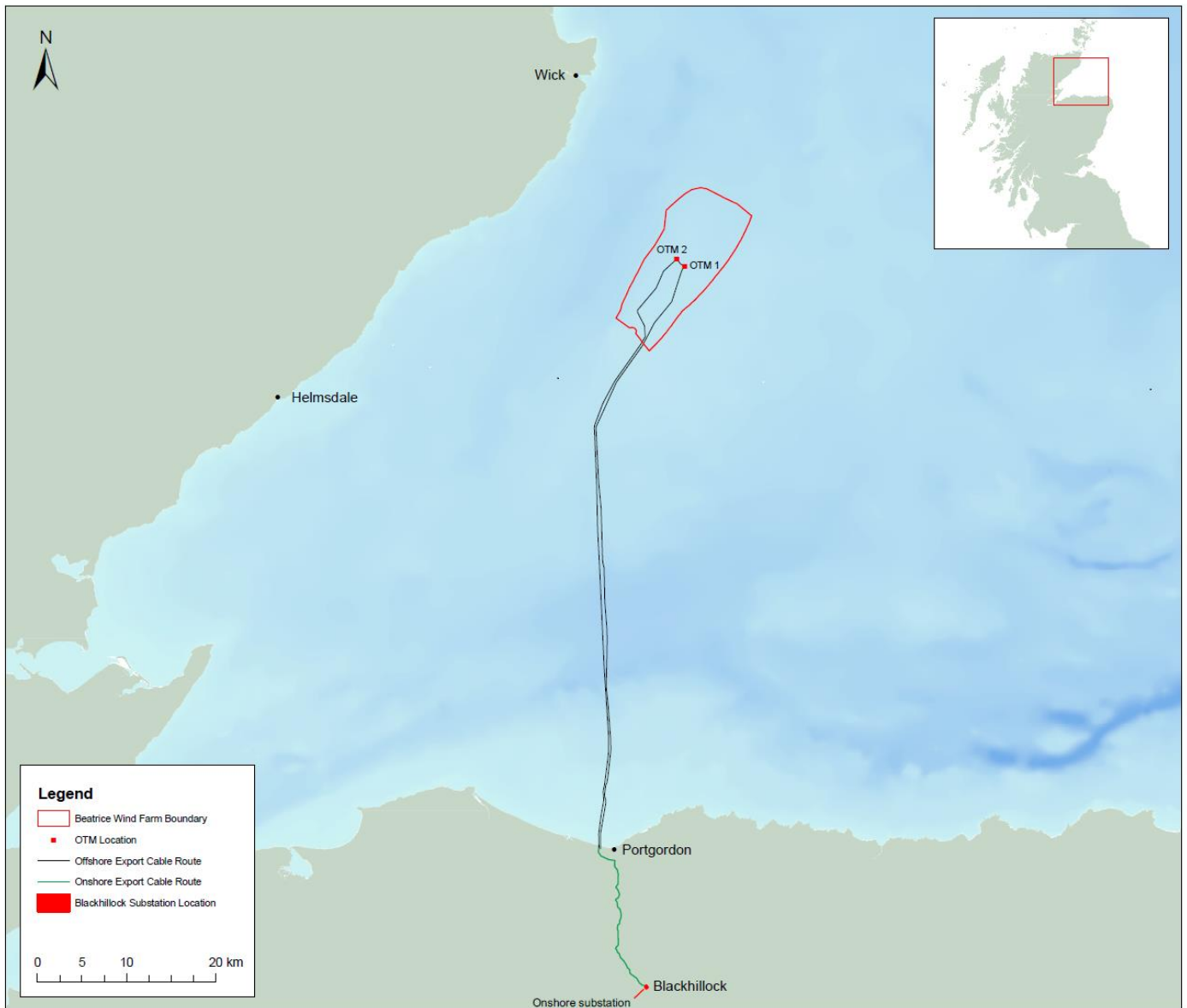

ANNEX B TO AMENDED STANDARD CONDITION E12-B1 (TRANSMISSION SYSTEM CIRCUIT)

The Beatrice transmission system is defined by the circuit diagram set out below:

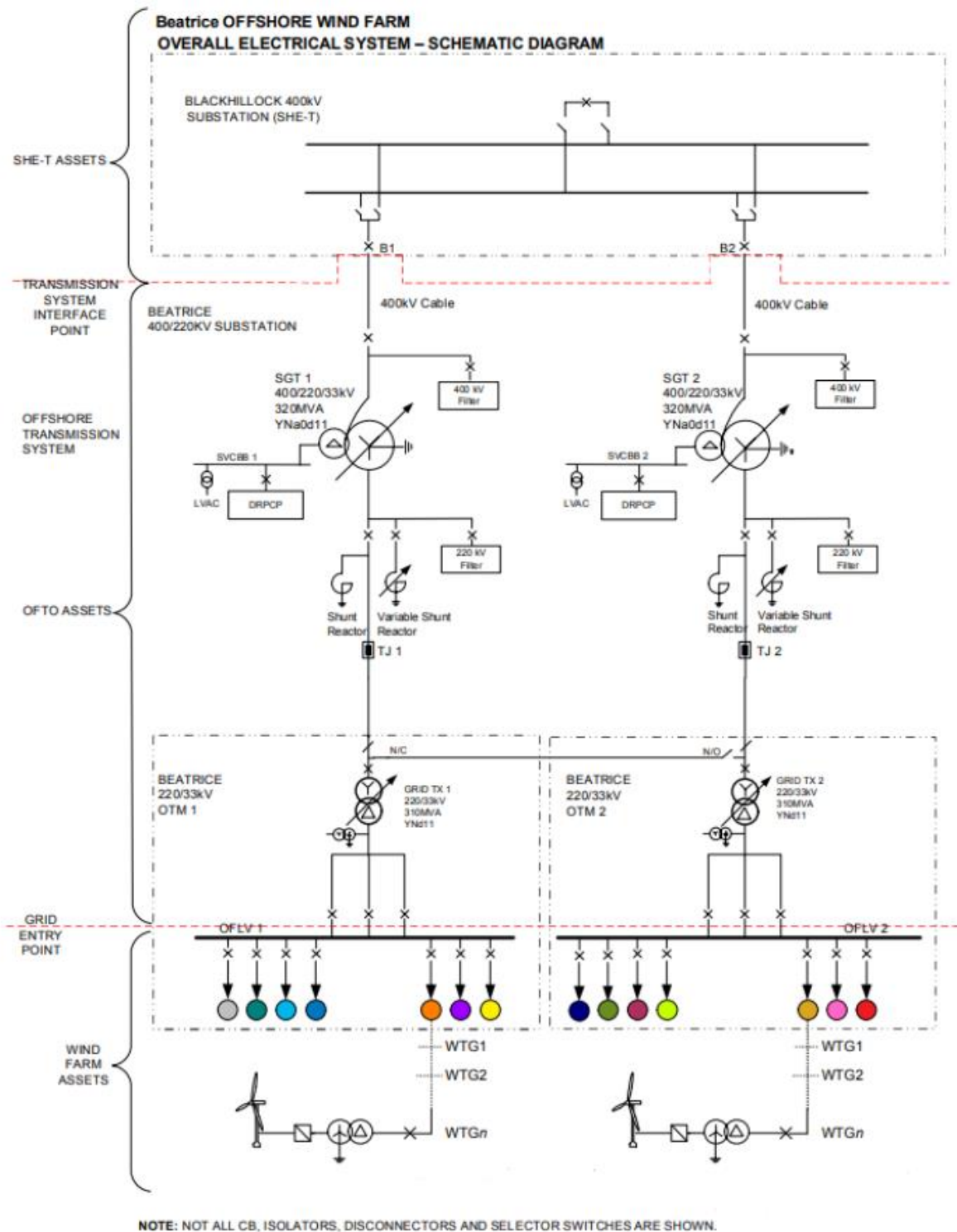

Amended Standard Condition E12–B2: Activities Restrictions

1. Subject to the provisions of paragraph 2 below (made in accordance with sections 7(2A)(a) and 7(2A)(b) of the Act), the licensee is authorised by paragraph 1 of Part I (Terms of the Licence) of this licence to participate in the transmission of electricity for the purpose of giving a supply to any premises or enabling a supply to be so given.
2. The licensee shall not:
 - (a) co-ordinate or direct the flow of electricity onto or over the whole or any part of the National Electricity Transmission System except where permitted to do so under the STC, subject to the approval of the Authority, or where required to do so by any other licence condition; and
 - (b) outside of the Transmission System Area, make available assets comprising part of the National Electricity Transmission System which are intended for the purpose of conveying or affecting the flow of electricity, except in relation to transmission assets specified in a direction issued by the Authority to the licensee pursuant to Standard Condition E21 (Offshore Transmission Owner of Last Resort).

Amended Standard Condition E12–C1: Conduct of the Transmission Business

1. The licensee shall conduct its Transmission Business in the manner best calculated to secure that, in complying with its obligations under this licence:
 - (a) the licensee;
 - (b) any Affiliate or Related Undertaking of the licensee that is a Subsidiary of, or is controlled by the Ultimate Controller of, the licensee including, for the avoidance of doubt, any Affiliate or Related Undertaking that is participating, or intends to participate in a competitive tender exercise to be appointed as an Offshore Transmission Owner;
 - (c) any user of the National Electricity Transmission System; and
 - (d) any other Transmission Licensee;obtains no unfair commercial advantage including, in particular, any such advantage from a preferential or discriminatory arrangement, being, in the case of such an advantage accruing to the licensee, one in connection with a business other than its Transmission Business.
2. Except insofar as the Authority may direct, the licensee shall secure and procure separate premises, equipment, systems for recording and storing data, facilities, staff, and property from those owned by the licensee and:
 - (a) those owned by the System Operator responsible for co-ordinating and directing the flow of electricity onto or over the National Electricity Transmission System; and
 - (b) those owned by any Associated Business of the licensee that is authorised to generate or supply electricity.

Amended Standard Condition E12–C2: Separation and Independence of the Transmission Business

1. The licensee, in carrying out its licensed activities, shall put in place and at all times maintain such systems of control and other governance arrangements which are necessary to ensure that the licensee complies with the obligations contained in Standard Condition E6 (Prohibition of Cross-subsidies), Standard Condition E7 (Restriction on Activity and Financial Ring Fencing), and Amended Standard Condition E12–C1 (Conduct of the Transmission Business).
2. Unless otherwise directed by the Authority, the licensee shall by no later than 30 days after this condition comes into force have in place a statement ("the statement"), approved by the Authority, describing the practices, procedures and systems which the licensee has adopted (or intends to adopt) to secure compliance with paragraph 1 and in particular (but without prejudice to the generality of paragraph 1) ensure compliance with paragraph 4.
3. Where the Authority does not indicate otherwise within 60 days of receipt of the statement, the statement shall be deemed to be approved by the Authority.
4. The licensee shall:
 - (a) maintain appropriate managerial and operational independence of the licensee from any Associated Business in undertaking its activities under its licence;
 - (b) except insofar as the Authority consents to the licensee not doing so, ensure that:
 - (i) any Associated Business of the licensee that is the System Operator responsible for co-ordinating and directing the flow of electricity onto or over the National Electricity Transmission System; and
 - (ii) any Associated Business of the licensee that is authorised to generate or supply electricityshall not use or have access to:
 - (aa) premises or parts of premises occupied by persons engaged in, or engaged in respect of, the management or operation of the Transmission Business or any External Transmission Activities;
 - (bb) systems for the recording, processing or storage of data to which persons engaged in, or engaged in respect of, the management or operation of the Transmission Business or any External Transmission Activities also have access;
 - (cc) equipment, facilities or property employed for the management or operation of the Transmission Business or any External Transmission Activities; or
 - (dd) the services of persons who are (whether or not as their principal occupation) engaged in, or in respect of, the management or operation of the Transmission Business or any External Transmission Activities; and
 - (iii) it can and does, insofar as is legally possible, prevent any person who has ceased to be engaged in, or in respect of, the management or operation of the

Transmission Business from being engaged in, or in respect of, the activities of any Associated Business of the licensee until the expiry of an appropriate time from the date on which he ceased to be engaged by the Transmission Business, where that Associated Business is either:

- (aa) the System Operator responsible for co-ordinating and directing the flow of electricity onto or over the National Electricity Transmission System;
or
- (bb) authorised to generate or supply electricity.

5. The managerial and operational independence referred to in paragraph 4(a) above shall include the establishment of separate boards of directors for the Transmission Business and for any Associated Businesses.
6. Further to paragraph 5, each member of such boards of directors or executives for Associated Businesses who is also a director of the offshore Transmission Business shall fulfil their role in relation to the taking of decisions as if he or she were a director of a legally incorporated company whose sole business is the business in respect of which the board he or she is a member of has been established.
7. The licensee shall revise the statement prepared in accordance with paragraph 2 when circumstances change such that the statement prepared in accordance with paragraph 2 no longer secures compliance with paragraphs 1 and 4 and such revision of the statement shall only become effective once the Authority has approved the revised statement in accordance with paragraph 2 or 3.
8. The licensee shall use its best endeavours to ensure compliance with the terms of the statement as from time to time revised and approved by the Authority.
9. The licensee shall publish a copy of the approved statement prepared in accordance with paragraph 2 (or the latest approved revision) on its company website within 7 days of its approval by the Authority.

Amended Standard Condition E12–C3: Restriction on use of certain information

1. Any information relating to or deriving from the management or operation of the Transmission Business shall, for the purposes of this condition, be treated as Confidential Information.
2. The licensee shall not (and shall procure that its Affiliates and Related Undertakings shall not) disclose or authorise access to Confidential Information:
 - (a) save to the extent provided by sub-paragraphs 3 (b) to (d) to such of its (or its Affiliates' or Related Undertakings') employees, agents, advisers, consultants or contractors as are engaged in, or in respect of, the management or operation of any other business (whether or not a separate business) of the licensee; or
 - (b) save to the extent permitted by paragraph 3, to any other person.
3. The licensee shall (and shall procure that its Affiliates and Related Undertakings shall) disclose or authorise access to Confidential Information only:
 - (a) in the following circumstances, namely:
 - (i) to such of its (or its Affiliates' or Related Undertakings') employees, agents, advisers, consultants or contractors as are engaged in, or in respect of, the management or operation of the Transmission Business or any External Transmission Activities and who require access to the information for that purpose;
 - (ii) to personnel of any holder of a Transmission Licence engaged in the External Transmission Activities of that Transmission Licence holder, to the extent necessary for the performance by such personnel of those External Transmission Activities, and the use by such personnel of that information for that purpose;

provided that effective arrangements are maintained in place at all times for ensuring that no further disclosure of any information supplied or obtained pursuant to this paragraph is made and that such information is used only for the purpose of the Transmission Business of the licensee or any External Transmission Activities of the licensee;
 - (b) where the licensee (or any Affiliate or Related Undertaking of the licensee) is required or permitted to disclose such information by virtue of:
 - (i) any requirement of a Competent Authority;
 - (ii) the Standard Conditions of any licence granted or taking effect as if granted under the Act or any document referred to in such a licence with which it is required by virtue of the Act or that licence to comply;
 - (iii) any other requirement of law; or
 - (iv) the rules of the Electricity Arbitration Association or of any judicial or other arbitral process or tribunal of competent jurisdiction;
 - (c) where such information was provided by or relates to any person who has notified (or otherwise agreed with) the licensee that it need not be treated as confidential;
 - (d) where such information, being information provided by or relating solely to the licensee, is placed by the licensee in the public domain; or

- (e) where such information is required for the purposes of assisting the System Operator, to prepare for and plan and develop the operation of the National Electricity Transmission System

and in each case the licensee shall disclose or authorise access to the Confidential Information only insofar as is necessary or appropriate in all the circumstances.

- 4. The licensee shall use all reasonable endeavours to ensure that any person who is in possession of or has access to Confidential Information in accordance with subparagraph 3(a) shall use such information only for the purposes of the Transmission Business or any External Transmission Activities.

Amended Standard Condition E12–C4: Appointment of Compliance Officer

1. The licensee shall, following consultation with the Authority, appoint a competent person (who shall be known as the "Compliance Officer") for the purpose of facilitating compliance by the licensee with this condition and with Standard Condition E6 (Prohibition of Cross-subsidies), Standard Condition E7 (Restriction on Activity and Financial Ring Fencing), Amended Standard Condition E12–C1 (Conduct of the Transmission Business), Amended Standard Condition E12 –C2 (Separation and Independence of the Transmission Business) and Amended Standard Condition E12–C3 (Restriction on use of certain information) (the "relevant duties").
2. The licensee shall at all times engage the services of the Compliance Officer for the performance of duties and tasks including those set out in paragraph 7 and any other duties and tasks as the licensee considers it appropriate to assign to him for the purposes specified in paragraph 1.
3. The licensee shall ensure that the Compliance Officer is not engaged in any activity of the Licensee's Transmission System other than the activity of being a Compliance Officer. Except to the extent that the Authority consents otherwise, the licensee shall ensure that the Compliance Officer is not engaged in any activity of any Associated Business other than the activity of being a Compliance Officer.
4. The licensee shall establish a compliance committee (being a committee of the board of directors of the licensee) for the purpose of overseeing and ensuring the performance of the duties and tasks of the Compliance Officer set out in paragraph 7 and the compliance of the licensee with its relevant duties. Such a compliance committee shall report to the board of directors of the licensee and shall include among its members a director responsible for day-to-day compliance with the activities of this licence and such persons from within the licensee's business as are responsible for the management of regulatory issues relating to the licence.
5. The licensee shall procure that the Compliance Officer:
 - (a) is provided with such staff, premises, equipment, facilities and other resources; and
 - (b) has such access to its premises, systems, information and documentationas, in each case, he might reasonably expect to require for the fulfilment of the duties and tasks assigned to him.
6. The licensee shall make available to the Compliance Officer a copy of any complaint or representation received by it from any person in respect of a matter arising under or by virtue of the relevant duties.
7. The duties and tasks assigned to the Compliance Officer shall include:
 - (a) providing relevant advice and information to the licensee for the purpose of ensuring its compliance with the relevant duties;
 - (b) monitoring the effectiveness of the practices, procedures and systems adopted by the licensee in accordance with the statement referred to in Amended Standard Condition E12–C2 (Separation and Independence of the Transmission Business) and reporting thereon. This shall include, but not be limited to:

- (i) ensuring the contracts of employment or engagement of relevant personnel shall include a statement on the importance of not disclosing information to other parties set out in paragraph 2 of Amended Standard Condition E12–C1 (Conduct of the Transmission Business). For this purpose a relevant member of staff or external person or consultant acting in such a role is anyone who are aware of any information which could enable any unfair commercial advantage being obtained including, in particular, any such advantage from a preferential or discriminatory arrangement, being, in the case of such an advantage accruing to the licensee, one in connection with a business other than its Transmission Business;
- (ii) ensuring that each of the processes required under the Standard Conditions is monitored in respect of the effectiveness of its practices, procedures, systems and the supervision and sign off process relating to the release of information which could enable an unfair commercial advantage to be obtained by the parties set out in paragraph 2 of Amended Standard Condition E12–C1 (Conduct of the Transmission Business);
- (c) advising whether, to the extent that the implementation of such practices, procedures and systems require the co-operation of any other person, they are designed so as to reasonably admit the required co-operation;
- (d) investigating any complaint or representation made available to him in accordance with paragraph 6;
- (e) recommending and advising upon the remedial action which any such investigation has demonstrated to be necessary or desirable;
- (f) providing relevant advice and information to the licensee (including individual directors of the licensee) and the compliance committee established under paragraph 4 of this condition, for the purpose of ensuring its implementation of:
 - (i) the practices, procedures and systems adopted in accordance with the statement referred to in paragraph 2 of Amended Standard Condition E12–C2 (Separation and Independence of the Transmission Business); and
 - (ii) any remedial action recommended in accordance with sub-paragraph (e);
- (g) reporting to the compliance committee any instances which come to his attention, relating to a member of any of the boards established under paragraph 5 of Amended Standard Condition E12–C2 (Separation and Independence of the Transmission Business), taking into account the interests of a business other than that in respect of which the board of which he is a member of has been established;
- (h) reporting annually to the compliance committee established under paragraph 4 of this condition, in respect of each year after this condition comes into force, as to his activities during the period covered by the report, including the fulfilment of the other duties and tasks assigned to him by the licensee; and
- (i) reporting annually to the board of directors of the licensee as to his activities during the period covered by the report, including the fulfilment of the other duties and tasks assigned to him by the licensee.

8. As soon as is reasonably practicable following each annual report of the compliance officer, the licensee shall produce a report in a form approved by the Authority detailing:
 - (a) its compliance during the Relevant Year with the relevant duties; and
 - (b) its implementation of the practices, procedures and systems adopted in accordance with the statement referred to in paragraph 2 of Amended Standard Condition E12–C2 (Separation and Independence of the Transmission Business).
9. The report produced in accordance with paragraph 8 shall in particular:
 - (a) detail the activities of the Compliance Officer during the Relevant Year;
 - (b) refer to such other matters as are or may be appropriate in relation to the implementation of the practices, procedures and systems adopted in accordance with the statement referred to in paragraph 2 of Amended Standard Condition E12–C2 (Separation and Independence of the Transmission Business); and
 - (c) set out the details of any investigations conducted by the compliance officer, including:
 - (i) the number, type and source of the complaints or representations on which the investigations were based;
 - (ii) the outcome of the investigations; and
 - (iii) any remedial action taken by the licensee following such investigations;
 - (d) be accompanied by a certificate, approved by a resolution of the board of directors of the licensee and signed by a director pursuant to that resolution, on the degree to which the licensee has achieved compliance with its relevant duties and that the report of the compliance officer fairly presents the licensee’s compliance with its relevant duties.
10. The licensee shall, as soon as reasonably practicable, submit to the Authority a copy of the report produced in accordance with paragraph 8 of this condition along with any supporting information and the licensee shall also publish a copy of the report on its website.

Amended Standard Condition E12–D1: Offshore Regulatory Reporting

Part A: Application and Purpose

1. The purpose of this condition is to secure the collection of specified information, to an appropriate degree of accuracy by the licensee so as to enable the Authority to effectively monitor the revenue and sulphur hexafluoride emissions of the consolidated Transmission Business.

Part B: Offshore Regulatory Reporting - Regulatory Instructions and Guidance and Specified Information

2. For the purposes of this condition:

"offshore regulatory reporting – regulatory instructions and guidance" means the Offshore Transmission Owner Regulatory Instructions and Guidance available on the Ofgem website, as modified from time to time under paragraph 15 and subject to paragraphs 16 to 21, which shall include (without limitation):

- (a) the definition of specified information, to be collected pursuant to this condition which includes:
 - (i) for the purposes of paragraph 7(a) (audited revenue return), all associated terms used in the derivation of the licensee's revenue entitlement as defined in the licensee's Transmission Licence;
 - (ii) for the purposes of paragraph 7(b) (cost reporting pack) all associated cost terms to reconcile the costs of the licensee to its Regulatory Accounts;
 - (iii) for the purposes of paragraph 7(c) (transmission system availability incentive template) the associated information and parameters used in the determination of the Transmission System Availability Incentive (AI_t);
 - (iv) for the purposes of paragraph 7(d) (incremental capacity adjustment template) the associated information and parameters used in the determination of the Incremental Capacity Incentive Adjustment (ICA_t);
 - (v) for the purposes of paragraph 7(e) (sulphur hexafluoride reporting requirements) the quantity of sulphur hexafluoride contained in the Licensee's Transmission System and the quantity of sulphur hexafluoride emitted in a Relevant Year; and
 - (vi) for the purposes of paragraph 7(f) (forecast revenue return), the Allowed Transmission Owner Revenue (OFTO_t), the actual revenue (the Regulated Transmission Revenue (AR_t)) and income derived from Excluded Services as defined in the licensee's Transmission Licence.
- (b) requirements for recording specified information which are reasonably necessary to enable an appropriate auditor to determine the accuracy and reliability of specified information;
- (c) requirements as to the form and manner in which specified information shall be provided to the Authority (including templates for doing so);

- (d) requirements as to the form and manner in which specified information shall be recorded and the standards of accuracy and reliability with which it shall be recorded; and
 - (e) requirements as to the timing of the provision of specified information to the Authority in respect of each Relevant Year.
3. The licensee shall:
- (a) establish and maintain appropriate systems, processes and procedures to measure and record specified information in respect of the Commencement Relevant Year and for each subsequent Relevant Year in accordance with the relevant offshore regulatory reporting - regulatory instructions and guidance (including any associated information therein) for the time being in force pursuant to this condition;
 - (b) maintain all systems of control and other governance arrangements that ensure the information collected and reported to the Authority is in all material respects accurate and complete and is fairly presented and that all such systems of control and other governance arrangements are kept under regular review by the directors of the licensee with a view to ensuring that they remain effective for this purpose; and
 - (c) provide all such assistance as may be reasonably required to permit the Authority to review such systems from time to time.
4. The licensee shall notify the Authority immediately if it discovers errors in the information or calculations used to derive the information submitted to the Authority under this licence condition.
5. The licensee shall collect the specified information required by the offshore regulatory reporting - regulatory instructions and guidance issued pursuant to this condition from the date on which such offshore regulatory reporting - regulatory instructions and guidance are issued by the Authority.

Part C: Information to be provided to the Authority

6. The licensee shall comply with the relevant provisions and information requirements of the offshore regulatory reporting - regulatory instructions and guidance issued pursuant to this condition.
7. Subject to paragraph 8, from the date of Asset Transfer, the licensee shall provide the Authority with:
- (a) the information specified in the templates for the audited revenue return contained in the offshore regulatory reporting - regulatory instructions and guidance by no later than 31 July following the end of the Relevant Year to which such information relates;
 - (b) the information specified in the templates for the cost reporting pack contained in the offshore regulatory reporting - regulatory instructions and guidance by no later than 31 July following the end of the Relevant Year to which such information relates;

- (c) the information specified in the template for the Transmission System Availability Incentive (AI_t) contained in the offshore regulatory reporting - regulatory instructions and guidance by no later than 31 July following the end of the Relevant Year to which the information relates;
 - (d) the information specified in the template for the Incremental Capacity Incentive Adjustment (ICA_t) contained in the offshore regulatory reporting - regulatory instructions and guidance by no later than 31 July following the end of the Relevant Year to which the information relates;
 - (e) the information specified in the template for sulphur hexafluoride reporting contained in the offshore regulatory reporting - regulatory instructions and guidance by no later than 31 July following the end of the Relevant Year to which the information relates;
 - (f) where requested by the Authority the information specified in the template for the Forecast Revenue Return contained in the offshore regulatory reporting - regulatory instructions and guidance, being the licensee's estimate of that information made on or before 1 April; and
 - (g) other requirements as to the timing of the provision of the information specified in the templates from the offshore regulatory reporting – regulatory instructions and guidance in respect of each Relevant Year, at such regular periods as the Authority determines.
8. Where licence grant falls between 1 January and 31 March of any year the reporting requirements specified in sub-paragraphs 7(a)-(e) (inclusive) will not be required on the first 31 July following licence grant. On the second 31 July following licence grant the information reporting requirements specified in sub-paragraphs 7(a)-(e) (inclusive) must cover the period from licence grant to the end of the following Relevant Year (t=2).
 9. Where licence grant falls outside of this period the reporting requirements specified in sub-paragraphs 7(a)-(e) (inclusive) shall be required on the first 31 July following licence grant unless alternative arrangements are consented to by the Authority.
 10. The reporting requirements specified in sub-paragraphs 7(a)-(e) (inclusive) shall be required on 31 July in all subsequent years unless the licensee is notified otherwise by the Authority.

Part D: Audit Requirements

11. The information referred to in sub-paragraphs 7(a) and 7(b) shall, at the Authority's direction, be accompanied by a report addressed to the Authority from the Auditors, stating whether in their opinion:
 - (a) the information provided in accordance with sub-paragraphs 7(a) and 7(b) has been properly prepared in accordance with the offshore regulatory reporting - regulatory instructions and guidance; and
 - (b) the amounts presented are in accordance with the licensee's records which have been maintained in accordance with paragraph 3 of this condition.

12. The licensee shall require that any report from the Auditors, referred to in paragraph 11, is accompanied by a letter from the Auditors to the Authority detailing the procedures that the Auditors have followed in reaching their opinion.
13. For the purposes of paragraph 11, the licensee shall at its own expense enter into a contract of appointment with the Auditors, which includes a term requiring that the audit be conducted in accordance with all relevant auditing standards in force on the last day of the Relevant Year to which the audit relates as would be appropriate.
14. The licensee shall (and must procure, insofar as it is able to do so, that any Affiliate or Related Undertaking of the licensee shall) co-operate fully with the Auditors so as to enable them to complete and report to the Authority on any audit carried out in accordance with paragraph 11.

Part E: Modification to the Offshore Regulatory Reporting -Regulatory Instructions and Guidance

15. Where the Authority considers that the offshore regulatory reporting - regulatory instructions and guidance should be modified in such way as is necessary to more effectively achieve the purposes of this condition, the Authority may, subject to paragraphs 16 to 19, modify the offshore regulatory reporting - regulatory instructions and guidance by issuing a direction to all relevant Transmission Licensees.
16. Before issuing a direction under paragraph 15, the Authority, by notice given to all relevant Transmission Licensees, shall:
 - (a) state that it proposes to make a modification, and set out the date on which it proposes that this should take effect;
 - (b) set out the text of the modification, the purpose and effect of the modification, and the reasons for proposing it; and
 - (c) specify the time (not less than 30 days from the date of the notice) within which representations or objections with respect to the proposed modification may be made,and consider any representations or objections which have been duly made and are not withdrawn.
17. When issuing a direction under paragraph 15 the Authority shall give reasons for its decision.
18. Where any proposed modification of the offshore regulatory reporting - regulatory instructions and guidance relates to a requirement to provide specified information to a greater level of accuracy than was previously required, the Authority may only make such modification with the consent of each licensee to whom such modification relates, provided that such consent is not unreasonably withheld or delayed by any relevant licensee.
19. Any modification of the offshore regulatory reporting - regulatory instructions and guidance under paragraph 15 to introduce an additional category of specified information or to enlarge an existing category of specified information shall not exceed

what may reasonably be requested from the licensee by the Authority under paragraph 1 of Standard Condition E5 (Provision of Information to the Authority).

20. The provisions of the offshore regulatory reporting - regulatory instructions and guidance may not exceed what is necessary to achieve the purposes of this condition.
21. Nothing in this condition should require the licensee to produce any documents which it could not be compelled to produce or give as evidence in civil proceedings before a court.

Amended Standard Condition E12-D2: Equity Transaction Reporting Requirement

Part A: Introduction

1. The purpose of this condition is to require the licensee to provide an annual submission to the Authority providing details of any relevant equity transactions.

Part B: Licensee's Obligations

2. Following the date of licence grant, the licensee shall prepare and submit to the Authority by 31 July of each year, details of any relevant equity transaction(s) that took place in the most recent relevant year except that the licensee may with the prior consent of the Authority not provide certain details of the relevant equity transaction where the Authority is satisfied that the licensee cannot provide such details.
3. Subject to paragraph 5, details to be prepared and submitted to the Authority for the purpose of paragraph 2 shall include:
 - (a) the date of the transaction(s);
 - (b) the value of the transaction(s);
 - (c) where applicable, the number of shares in the licensee transferred, issued or bought back and the percentage of the total shares of the licensee this represents; and
 - (d) where applicable, the percentage of the licensee now owned by the new ultimate controller(s).
4. The licensee's initial submission to the Authority under paragraph 2 should also include details of the quantity and value of equity invested in the licensee at the point of asset transfer.
5. Where a relevant equity transaction occurs as part of a transaction involving the issue, sale (or otherwise transfer) or buy back of shares in a company of which the licensee or a holding company of the licensee is a subsidiary, details of the value of the transaction provided to the Authority under paragraph 3 shall relate only to the value placed on the licensee for the purpose of that transaction.
6. Where licence grant falls between 1 January and 31 March of any year the reporting requirements specified in paragraph 2 will not be required on the first 31 July following licence grant. In such circumstances the information reporting requirements specified in paragraph 2 shall be prepared and submitted on the second 31 July following licence grant and must cover the period from licence grant to the end of the following relevant year (t=2).

Amended Standard Condition E12–J1: Not Used

Amended Standard Condition E12–J2: Restriction of Transmission Revenue: Revenue from Transmission Owner Services

1. The purpose of this condition is to establish the revenue restriction that determines the Allowed Transmission Owner Revenue (OFTO_t) that the licensee may earn from its Transmission Owner Services in any Relevant Year.
2. The revenue entitlement of the licensee, determined in accordance with paragraph 4 below, shall commence upon the date this condition comes into force.
3. The licensee shall take all appropriate steps within its power to ensure that in any Relevant Year t, Regulated Transmission Revenue (AR_t) shall not exceed the Allowed Transmission Owner Revenue (OFTO_t) calculated in accordance with the formula given in paragraph 4 below.

Formula for Allowed Transmission Owner Revenue (OFTO_t)

4. For the purposes of this condition, Allowed Transmission Owner Revenue (OFTO_t) shall take the value of zero in all Relevant Years preceding the Commencement Relevant Year (t=1) and thereafter Allowed Transmission Owner Revenue (OFTO_t) shall be calculated in accordance with the following formula:

$$OFTO_t = BR_t + PT_t + PA_t - K_t \quad (1)$$

where:

OFTO_t means Allowed Transmission Owner Revenue in the Relevant Year t.

BR_t means Base Transmission Revenue which shall be calculated as:

$$BR_t = PR_t(TRS_t(RIT_t \times BI_{TRS} + (1 - BI_{TRS})) + MRA_t(RIT_t \times BI_{MRA} + (1 - BI_{MRA})) + PTRAt(RIT_t \times BI_{PTRA} + (1 - BI_{PTRA}))) \quad (2)$$

where:

TRS_t means the Tender Revenue Stream and shall take the value of £18,340,000, in Tender Relevant Year prices;

MRA_t means the Market Rate Revenue Adjustment and shall take the value set out in any direction issued pursuant to Amended Standard Condition E12–A2 (Market Rate Revenue Adjustment), otherwise it shall take the value zero;

PTRAt means the Post Tender Revenue Adjustment and shall take the value set out in any direction issued pursuant to Amended Standard Condition E12–A3 (Post Tender Revenue Adjustment), otherwise it shall take the value zero;

BI_{TRS} represents the proportion of the Tender Revenue Stream to be indexed and shall be 100% in this licence;

BI_{MRA} represents the proportion of the Market Rate Revenue Adjustment

to be indexed and shall be 100% in this licence;

BI_{PTRA} represents the proportion of the Post Tender Revenue Adjustment to be indexed and shall be 100% in this licence;

PR_t means the proportion of revenue term which adjusts the Allowed Transmission Owner Revenue (OFTOt) for partial years. It represents the proportion of TRS_t , MRA_t and $PTRA_t$ to be recoverable in that Relevant Year and shall take the value 1, except:

- (a) in respect of the period before Asset Transfer in the Commencement Relevant Year where it shall take the value zero.
- (b) in respect of the period on or after Asset Transfer in the Commencement Relevant Year where it shall take the value determined by the following formula:

$$PR_1 = 1 - \left(\frac{\text{No of days between date of asset transfer and start of commencement relevant year}}{365.25} \right) \quad (3)$$

- (c) in respect of the Closing Relevant Year where it shall take the value determined by the following formula:

$$PR_{24} = \left(\frac{\text{No of days between date of asset transfer and start of commencement relevant year}}{365.25} \right) \quad (4)$$

- (d) in all Relevant Years subsequent to the Closing Relevant Year, where it shall take the value zero.

RIT_t is the revenue indexation adjustment term for the Relevant Year t, and shall be derived from the following formula:

$$RIT_t = \frac{RPI(\text{September})_{t-1}}{RPI(\text{base date})} \quad (5)$$

where:

$RPI(\text{September})_t$ means the Retail Prices Index Number for the month of September in Relevant Year t; and

$RPI(\text{base date})$ means the Retail Prices Index Number for the month in which the Base Date occurred;

however:

in the Tender Relevant Year and in each Relevant Year prior

to the first indexation adjustment, RIT_t shall take the value 1;
and

the first revenue indexation adjustment for Relevant Year t shall only occur when in Relevant Year t-1 the month of September has occurred since the Base Date.

PT_t means the pass-through revenue adjustment term, whether of a positive or of a negative value, made in the Relevant Year t in respect of Allowed Pass-through Items as derived in accordance with Amended Standard Condition E12–J3 (Restriction of Transmission Revenue: Allowed Pass-through Items);

PA_t means the performance availability revenue adjustment term, whether of a positive or of a negative value, made in the Relevant Year t in respect of annual revenue adjustments as derived in accordance with Amended Standard Condition E12–J4 (Restriction of Transmission Revenue: Annual Revenue Adjustments);

K_t means the revenue restriction correction factor, which is the difference between the Regulated Transmission Revenue (AR_{t-1}) and the allowed transmission revenue ($OFTO_{t-1}$) in the previous year, whether of a positive or of a negative value, which takes the value zero in the first Relevant Year ($t=1$). In subsequent years, it is calculated in accordance with the formula below:

$$K_t = (AR_{t-1} - OFTO_{t-1}) \times \left[1 + \frac{(I_t + PI_t)}{100} \right] \quad (6)$$

where:

AR_{t-1} means the Regulated Transmission Revenue in respect of the Relevant Year t-1.

$OFTO_{t-1}$ means the Allowed Transmission Owner Revenue in the Relevant Year t-1.

I_t means the Average Specified Rate in the Relevant Year t.

PI_t means the penalty interest rate in Relevant Year t, which is equal to:

(a) where

$$AR_{t-1} > 1.04 \times OFTO_{t-1} \quad (7)$$

the penalty interest rate shall be 4; and

(b) otherwise, it shall take the value zero.

Amended Standard Condition E12–J3: Restriction of Transmission Revenue: Allowed Pass-through Items

1. The purpose of this condition is to provide for revenue adjustments to reflect certain costs that can be passed through to consumers as part of Allowed Transmission Owner Revenue (OFTO_t).
2. For the purposes of paragraph 4 of Amended Standard Condition E12–J2 (Restriction of Transmission Revenue: Revenue from Transmission Owner Services) the pass-through revenue adjustment term (PT_t) is derived from the following formula

$$PT_t = LF_t + RB_t + CEL_t + DC_t + IAT_t + TPD_t + TCA_t + MCA_t + CEA_t - RFG_t \quad (8)$$

where:

- LF_t means the licence fee cost adjustment term, whether of a positive or of a negative value, and shall be determined in accordance with paragraph 3.
- RB_t means the network rates cost adjustment term, whether of a positive or of a negative value, and shall be determined in accordance with paragraphs 4 and 5.
- CEL_t means the Crown Estate Lease cost adjustment term, whether of a positive or negative value, and shall be determined in accordance with paragraph 6.
- DC_t means the decommissioning cost adjustment term and shall be determined in accordance with paragraphs 7 to 13.
- IAT_t means the Income Adjusting Event revenue adjustment term, whether of a positive or of a negative value, and shall be determined in accordance with paragraphs 14 to 24.
- TPD_t means the temporary physical disconnection payment term and shall be determined in accordance with paragraph 25.
- TCA_t means the tender fee cost adjustment term, whether of a positive or of a negative value, and shall be determined in accordance with paragraph 26.
- MCA_t means the Marine and Coastal Access Act 2009 cost adjustment term and shall be determined in accordance with paragraphs 27 to 33.
- CEA_t means the Contingent Event revenue adjustment term and shall be determined in accordance with paragraphs 34 to 45.
- RFG_t means the Refinancing Gain Share determined in accordance with paragraphs 46 to 63.

Formula for the Licence Fee Cost Adjustment (LF_t)

3. For the purposes of paragraph 2, LF_t is an amount in respect of licence fee payments and means the amount equal to the payments made by the licensee, in the Relevant Year t, in accordance with its obligations set out in Standard Condition A4 (Payments by the Licensee to the Authority).

Formula for the Network Rates Cost Adjustment (RB_t)

4. For the purposes of paragraph 2, RB_t is an amount in respect of Networks Rates payments and means, subject to paragraph 5 of this condition, the amount equal to the rates payments made by the licensee in the Relevant Year t .
5. The licensee shall at the time of Network Rates Revaluation use reasonable endeavours to minimise the costs that it will incur in respect of Network Rates.

Formula for the Crown Estate Lease Cost Adjustment (CEL_t)

6. For the purposes of paragraph 2, CEL_t is an amount equal to the payments made by the licensee to the Crown Estate, in the Relevant Year t , in accordance with its obligations set out in its Crown Estate Lease in respect of the:
 - (a) annual rent of the seabed; and
 - (b) legal expenses of the Crown Estate for the preparation, negotiation and completion of the Crown Estate Lease.

Formula for the Decommissioning Cost Adjustment (DC_t)

7. Where the licensee considers, and can provide supporting evidence, that there will be additional costs and/or expenses in relation to the licensee's obligations with respect to decommissioning of the Licensee's Transmission System that have arisen due to a change in legislative requirements, then the licensee shall give written notice of this change to the Authority.
8. A notice received by the Authority under paragraph 7 shall give particulars of:
 - (a) the change in legislative requirements to which the notice relates and the reason(s) why the licensee considers that it will face additional costs and/or expenses in complying with those obligations, and demonstrate that such costs and/or expenses are not included within the Allowed Transmission Owner Revenue ($OFTO_t$);
 - (b) the expected amount of any change in costs and/or expenses that can be demonstrated by the licensee to be caused by the change in decommissioning requirements and how the amount of these costs and/or expenses has been calculated;
 - (c) the amount of any allowed revenue adjustment, proposed as a consequence of the change in decommissioning requirements and how this allowed revenue adjustment has been calculated; and
 - (d) any other analysis or information, which the licensee considers sufficient to enable the Authority to fully assess the change in legislative requirements to which the notice relates.
9. If the Authority considers that the analysis or information received under paragraph 8 is insufficient to enable the Authority to assess whether a change in decommissioning requirements has occurred and/or the amount of any revenue adjustment that might be approved, the Authority can request that the supporting evidence be supplemented with any additional information that it considers appropriate. If the Authority requests that the supporting evidence be supplemented with additional information, the licensee shall

give such information to the Authority within one month of the Authority requesting such information.

10. A notice referred to in paragraph 7 shall be given as soon as is reasonably practicable after the occurrence of the change in legislative requirements, and, in any case, not later than three months after the end of the Relevant Year in which the change in requirements occurs.
11. The Authority shall determine:
 - (a) whether any or all of the costs and/or expenses given in a notice pursuant to paragraph 7 were caused by the change in legislative requirements;
 - (b) if so, whether the amount of the proposed revenue adjustment ensures that the financial position and performance of the licensee are, insofar as is reasonably practicable, the same as if that change in legislative decommissioning requirements had not taken place, and if not, the Authority shall determine what revenue adjustment would secure that effect; and
 - (c) the periods, if any, over which the revenue adjustment determined by the Authority should apply.
12. In relation to the Relevant Year t , the decommissioning cost adjustment term (DC_t) shall be:
 - (a) the value determined by the Authority under paragraph 11 above; or
 - (b) if the Authority has not requested additional information under paragraph 9 and the Authority has not made a determination under paragraph 11 above within three months of the date on which the notice given by the licensee was received by the Authority, the amount of the allowed revenue adjustment proposed by the licensee in that notice given to the Authority; or
 - (c) if the Authority requests additional information under paragraph 9 and the Authority has not made a determination under paragraph 11 above within three months of receiving all additional information requested, the amount of the allowed revenue adjustment proposed by the licensee in the notice given to the Authority; or
 - (d) in all other cases the value zero, including situations where the Authority has not made a determination under paragraph 11 above within three months of the date on which the notice given by the licensee was received by the Authority, or within three months of the date on which the Authority received additional information if requested under paragraph 9, and the Authority has, before the end of the appropriate three month period, informed the licensee that the Authority considers that the analysis or information provided in accordance with paragraphs 8 and/or 9 is insufficient to enable the Authority to assess whether additional costs and/or expenses have occurred and/or the amount of any allowed revenue adjustment.
13. The Authority's decision in relation to any notice given under paragraph 7 shall be in writing, shall be copied to the licensee and shall be published.

Formula for the Income Adjusting Event Revenue Adjustment (IAT_t)

14. Where the licensee considers, and can provide supporting evidence that, in respect of Relevant Year t, there have been costs and/or expenses that have been incurred or saved by an Income Adjusting Event, then the licensee shall give written notice of this Income Adjusting Event to the Authority.
15. An Income Adjusting Event in Relevant Year t may arise from any of the following:
 - (a) an event or circumstance constituting Force Majeure;
 - (b) an event or circumstance resulting from an amendment to the STC not allowed for when the Allowed Transmission Owner Revenue (OFTO_t) of the licensee was determined for the Relevant Year t; and
 - (c) an event or circumstance other than listed above which, in the opinion of the Authority, is an Income Adjusting Event and is approved by it as such in accordance with paragraph 21 of this licence condition,

where the event or circumstance has, for Relevant Year t, increased or decreased costs and/ or expenses by more than £1,000,000 (the "threshold amount").
16. A notice received by the Authority under paragraph 14 shall give particulars of:
 - (a) the event or circumstance to which the notice relates and the reason(s) why the licensee considers this event or circumstance to be an Income Adjusting Event;
 - (b) the amount of any change in costs and/or expenses that can be demonstrated by the licensee to have been caused or saved by the event or circumstance and how the amount of these costs and/or expenses has been calculated, including the extent to which the licensee has claimed or intends to claim under other routes of recourse for any costs and/or expenses arising out of or relating to the event or circumstance;
 - (c) the amount of any allowed revenue adjustment proposed as a consequence of that event or circumstance and how this allowed revenue adjustment has been calculated; and
 - (d) any other analysis or information, which the licensee considers sufficient to enable the Authority and the relevant parties to fully assess the event or circumstance to which the notice relates.
17. If the Authority considers that the analysis or information received under paragraph 16 is insufficient to enable both the Authority and the relevant parties to assess whether an Income Adjusting Event has occurred and/or the amount of any revenue adjustment that might be approved, the Authority can make a request or requests that the supporting evidence be supplemented with any additional information that it considers appropriate. If the Authority requests that the supporting evidence be supplemented with additional information, the licensee shall give such information to the Authority within one (1) month of the Authority requesting such information or within such extended time as permitted by the Authority.
18. A notice of an Income Adjusting Event referred to in paragraph 14 shall be given as soon as is reasonably practicable after the occurrence of the Income Adjusting Event,

and, in any case, not later than three (3) months after the end of the Relevant Year in which it occurs.

19. The Authority will make public, excluding any confidential information, any notice of an Income Adjusting Event as soon as is reasonably practicable following its receipt.
20. Any notice received by the Authority under paragraph 14 above should clearly identify whether any of the information contained in the notice is of a confidential nature. The Authority shall make the final determination as to confidentiality having regard to:
 - (a) the need to exclude from disclosure, so far as is reasonably practicable, information whose disclosure the Authority considers would or might seriously prejudicially affect the interests of a person to which it relates; and
 - (b) the extent to which the disclosure of the information mentioned in sub-paragraph 20(a) is necessary for the purposes of enabling the relevant parties to fully assess the event to which the notice relates.
21. The Authority shall determine (after consultation with the licensee and such other persons as it considers desirable):
 - (a) whether any or all of the costs and/or expenses given in a notice pursuant to paragraph 14 were caused or saved by an Income Adjusting Event;
 - (b) whether the event or circumstance has increased or decreased the costs and/or expenses given in the notice pursuant to paragraph 14 by more than the threshold amount; and
 - (c) if so:
 - i. subject to sub-paragraph (iii), whether the amount of the proposed revenue adjustment ensures that the financial position and performance of the licensee are, insofar as is reasonably practicable, the same as if that Income Adjusting Event had not taken place, and if not, the Authority shall determine what revenue adjustment would secure that effect. Such adjustment shall be:
 - a. where the Income Adjusting Event relates to an Uninsurable event or circumstance, reduced by:
 - i. if the licence was granted on or before 28 November 2018, the amount of the insurance deductible set out in the invitation to tender questionnaire submitted in respect of this licence pursuant to the Tender Regulations; or
 - ii. if the licence was granted after 28 November 2018, either £5 million or the insurance deductible set out in the invitation to tender questionnaire submitted in respect of this licence pursuant to the Tender Regulations, whichever is greater; and
 - b. for the avoidance of doubt, reduced by costs and/or expenses caused by the Income Adjusting Event that are recovered by other routes of

recourse available to the licensee, including, but not limited to, commercial arrangements;

unless, and to the extent that, the Authority has already applied such reductions to a previous revenue adjustment related to the same event or circumstance as that set out in the notice pursuant to paragraph 14;

- ii. subject to sub-paragraph (iii), the periods, if any, over which the revenue adjustment determined by the Authority should apply; and
 - iii. where it is not yet possible to make a final determination under sub-paragraphs (c)(i) and (c)(ii) above, the Authority may direct a partial amount of revenue adjustment, if any, pending the final determination of amount, such final determination to be made as soon as is reasonably practicable.
22. In relation to the Relevant Year t , the income adjusting event revenue adjustment (IAT_t) shall be:
- (a) the value, or relevant proportion of the value, determined by the Authority under paragraph 21 above; or
 - (b) if the Authority has not requested additional information under paragraph 17 and the Authority has not made a determination under paragraph 21 above within three (3) months (excluding the duration of any consultation under paragraph 21) of the date on which notice of an Income Adjusting Event was received by the Authority, the amount of the allowed revenue adjustment proposed as a consequence of the event in the notice given to the Authority under paragraph 14; or
 - (c) if the Authority requests additional information under paragraph 17 and the Authority has not made a determination under paragraph 21 above within three (3) months (excluding the duration of any consultation under paragraph 21) of receiving all additional information requested, the amount of the allowed revenue adjustment proposed by the licensee in the notice given to the Authority under paragraph 14; or
 - (d) in all other cases the value zero (0), including situations where the Authority has not made a determination under paragraph 21 above within three (3) months (excluding the duration of any consultation under paragraph 21) of the date on which the notice was received by the Authority, or within three (3) months (excluding the duration of any consultation under paragraph 21) of the date on which the Authority received additional information if requested under paragraph 17, and the Authority has, before the end of that relevant period, informed the licensee that the Authority considers that the analysis or information provided in accordance with paragraphs 16 and/or 17 is insufficient to enable the Authority to assess whether an Income Adjusting Event has occurred and/or the amount of any allowed revenue adjustment.
23. The Authority's decision in relation to any notice given under paragraph 14 shall be in writing, shall be copied to the licensee and shall be published.

24. The Authority may amend or revoke an approval of an Income Adjusting Event and revenue adjustment with the consent of the licensee, following consultation with the licensee and relevant parties, and any such amendment or revocation of any Income Adjusting Event and revenue adjustment shall be in writing, shall be copied to the licensee and shall be published.

Formula for the Temporary Physical Disconnection Payment (TPD_t)

25. For the purposes of paragraph 2, TPD_t shall be an amount equal to the interruption payments made by the System Operator in the licensee's Transmission System Area and charged by the System Operator to the Transmission Licensee in accordance with the STC within each respective Relevant Year. Such costs shall include any financing or other costs such as to ensure that the financial position and performance of the licensee is, insofar as is reasonably practicable, the same as if those costs had not been incurred.

Formula for the Tender Fee Cost Adjustment (TCA_t)

26. For the purposes of paragraph 2, TCA_t shall be an amount, whether of a positive or of a negative value, representing:
- (a) the payments made by the licensee to the Authority in accordance with the Tender Regulations with respect to the to the recovery of the Authority's tender costs. Where the payments have been made in relation to an application for the grant of more than one licence, the licensee shall attribute an appropriate proportion of the relevant payment made to the Authority; and
 - (b) any re-payments made by the Authority to the licensee in accordance with the Tender Regulations as a result of the payments collected by the Authority exceeding its tender costs. Where the re-payments have been made in relation to an application for the grant of more than one licence, the licensee shall be attributed an appropriate proportion of the relevant re-payment made by the Authority.

Formula for the Marine and Coastal Act 2009 Cost Adjustment (MCA_t)

27. Where the licensee considers, and can provide supporting evidence, that there will be additional costs and/or expenses in relation to additional obligations imposed on the licensee with respect to the introduction of the Marine and Coastal Access Act 2009, then the licensee may give written notice of these changes to the Authority.
28. A notice received by the Authority under paragraph 27 shall give particulars of:
- (a) the additional obligations to which the notice relates and the reason(s) why the licensee considers that it will face additional costs and/or expenses in complying with those additional obligations, and demonstrate that such costs and/or expenses are not included within the Allowed Transmission Owner Revenue (OFTO_t);
 - (b) the expected amount of any change in costs and/or expenses that can be demonstrated by the licensee to be caused by the introduction of those new obligations under the Marine and Coastal Access Act 2009 and how the amount of these costs and/or expenses has been calculated;
 - (c) the amount of any allowed revenue adjustment proposed as a consequence of the licensee incurring additional obligations in relation to the Marine and Coastal

Access Act 2009 requirements and how this allowed revenue adjustment has been calculated; and

- (d) any other analysis or information, which the licensee considers sufficient to enable the Authority to fully assess the additional obligations to which the notice relates.
29. If the Authority considers that the analysis or information received under paragraph 28 above is insufficient to enable the Authority to assess whether additional obligations have been imposed on the licensee and/or the amount of any revenue adjustment that might be approved, the Authority can request that the supporting evidence be supplemented with any additional information that it considers appropriate. If the Authority requests that the supporting evidence be supplemented with additional information, the licensee shall give such information to the Authority within one month of the Authority requesting such information.
30. A notice referred to in paragraph 27 shall be given as soon as is reasonably practicable after the new obligations imposed by the Marine and Coastal Access Act 2009 take effect, and, in any event, not later than three months after the end of the Relevant Year in which they take effect.
31. The Authority shall determine:
- (a) whether any or all of the costs and/or expenses given in a notice pursuant to paragraph 27 were caused by the introduction of new obligations as a consequence of the Marine and Coastal Access Act 2009 requirements and not already incorporated within Allowed Transmission Owner Revenue (OFTO_t);
 - (b) if so, whether the amount of the proposed revenue adjustment ensures that the financial position and performance of the licensee are, insofar as is reasonably practicable, the same as if the additional obligations had not been implemented, and if not, the Authority shall determine what revenue adjustment would secure that effect; and
 - (c) the periods, if any, over which the revenue adjustment determined by the Authority should apply.
32. In relation to the Relevant Year *t*, the Marine and Coastal Act 2009 cost adjustment term (MCA_t) shall be:
- (a) the value determined by the Authority under paragraph 31 above; or
 - (b) if the Authority has not requested additional information under paragraph 29 and the Authority has not made a determination under paragraph 31 above within three months of the date on which the notice was received by the Authority under paragraph 27, the amount of the allowed revenue adjustment proposed by the licensee in that notice given to the Authority; or
 - (c) if the Authority requests additional information under paragraph 29 and the Authority has not made a determination under paragraph 31 above within three months after receiving all additional information requested, the amount of the allowed revenue adjustment proposed by the licensee in the notice given to the Authority under paragraph 27; or

- (d) in all other cases the value zero, including situations where the Authority has not made a determination under paragraph 31 above within three months of the date on which the notice given by the licensee was received by the Authority, or within three months of the date on which the Authority received additional information if requested under paragraph 29, and the Authority has, before the end of the appropriate three month period, informed the licensee that the Authority considers that the analysis or information provided in accordance with paragraphs 28 and/or 29 is insufficient to enable the Authority to assess whether additional costs and/or expenses have occurred and/or the amount of any allowed revenue adjustment.
33. The Authority's decision in relation to any notice given under paragraph 27 shall be in writing, shall be copied to the licensee and shall be published.

Formula for the Contingent Event Revenue Adjustment (CEAt)

34. Where the licensee considers, and can provide supporting evidence that, in respect of Relevant Year t, there have been costs and/or expenses that have been incurred by the licensee in respect of a Contingent Event, then the licensee shall give written notice of this Contingent Event to the Authority (in respect of which, the licensee shall not also be entitled to serve a notice in respect of such costs and/or expenses under paragraph 14 of this Amended Standard Condition).
35. A notice provided to the Authority under paragraph 34 shall give particulars of:
- (a) the Contingent Event to which the notice relates;
 - (b) the extent to which, if at all, the licensee has mitigated or can mitigate any losses arising out of or relating to the Contingent Event, including but not limited to commercial solutions available to it;
 - (c) the amount of any change in costs and/or expenses that can be demonstrated by the licensee to have been caused by the Contingent Event and how the amount of these costs and/or expenses has been calculated;
 - (d) the amount of any allowed revenue adjustment proposed as a consequence of the Contingent Event and how this allowed revenue adjustment has been calculated; and
 - (e) any other analysis or information, which the licensee considers sufficient to enable the Authority and the relevant parties to fully assess the Contingent Event to which the notice relates.
36. If the Authority considers that the analysis or information provided under paragraph 35 above is insufficient to enable both the Authority and the relevant parties to assess whether a Contingent Event has occurred and/or the amount of any allowed revenue adjustment that might be approved, the Authority can request that the supporting evidence be supplemented with any additional information that it considers appropriate. If the Authority requests that the supporting evidence be supplemented with additional information, the licensee shall provide such information to the Authority within one (1) month of the Authority requesting the information, or within the period otherwise directed by the Authority.

37. A notice of a Contingent Event shall be provided as soon as is reasonably practicable after the occurrence of the Contingent Event, and, in any case, not later than three (3) months after the end of the Relevant Year in which it occurs.
38. The Authority will make public, excluding any confidential information, any notice of a Contingent Event as soon as is reasonably practicable following its receipt.
39. Any notice provided to the Authority under paragraph 34 should clearly identify whether any of the information contained in the notice is of a confidential nature. The Authority shall make the final determination as to confidentiality having regard to:
 - (a) the need to exclude from disclosure, so far as is reasonably practicable, information whose disclosure the Authority considers would or might seriously prejudicially affect the interests of a person to which it relates; and
 - (b) the extent to which the disclosure of the information mentioned in sub-paragraph 39(a) is necessary for the purposes of enabling the relevant parties fully to assess the Contingent Event to which the notice relates.
40. The Authority shall determine (after consultation with the licensee and such other persons as it considers desirable) whether a Contingent Event has occurred and, if so, determine the following in order to calculate the value of the Contingent Event revenue adjustment:
 - (a) whether any or all of the costs and/or expenses given in a notice under paragraph 34 were caused by the Contingent Event;
 - (b) whether the costs and/or expenses were incurred economically and efficiently;
 - (c) whether the costs and/or expenses are net of all reasonable mitigation of the costs and/or expenses that the licensee has available to it, including but not limited to commercial recovery;
 - (d) if so, whether the amount of the proposed revenue adjustment ensures that the financial position and performance of the licensee are, insofar as is reasonably practicable, the same as if the Contingent Event had not taken place (save for any deductions under sub-paragraphs 40(b) and 40(c)), and if not, the Authority shall determine what revenue adjustment shall secure that effect; and
 - (e) the periods, if any, over which the revenue adjustment determined by the Authority shall apply.
41. The allowed revenue adjustment ($CEA_{(t)}$) for Relevant Year t shall be:
 - (a) the value determined by the Authority under paragraph 40; or
 - (b) the value zero where the Authority determines that a Contingent Event has not occurred; or
 - (c) the value proposed by the licensee in the notice provided to the Authority under paragraph 34 where the Authority has not requested additional information under paragraph 36 and the Authority has not made a determination under paragraph 40 within three (3) months, or such other period that the Authority notifies to the licensee, of the date on which notice of a Contingent Event was provided to the Authority; or

- (d) the value proposed by the licensee in the notice provided to the Authority under paragraph 34 where the Authority requests additional information under paragraph 36 and the Authority has not made a determination under paragraph 40 within three (3) months, or such other period that the Authority notifies to the licensee, after receiving the additional information requested; or
 - (e) the value zero in situations where the licensee fails to provide, within the relevant time period, additional analysis or information requested by the Authority under paragraph 36; or
 - (f) the value zero in all other cases, including situations where the Authority has not made a determination under paragraph 40 within three (3) months of the date on which the notice under paragraph 34 was provided to the Authority or within three (3) months of the date on which the Authority received the additional information requested under paragraph 36 and the Authority has, before the end of the relevant three (3) month period, informed the licensee that the Authority considers that the analysis or information provided in accordance with paragraphs 35 and/or 36 is insufficient to enable the Authority to assess whether the Contingent Event occurred and/or the amount of any allowed revenue adjustment.
42. The Authority’s decision in relation to any notice provided under paragraph 34, shall be in writing, shall be copied to the licensee and shall be published (excluding any confidential information).
43. The Authority may revoke an approval of a Contingent Event and allowed revenue adjustment with the consent of the licensee, following consultation with the licensee and relevant parties, and any such revocation of any Contingent Event and allowed revenue adjustment shall be in writing, shall be copied to the licensee and shall be published.
44. Where the Authority directs a revenue adjustment under paragraph 41 and it subsequently transpires that all costs and/or expenses allowed for under that revenue adjustment have not been incurred in full, the Authority may retrospectively vary the allowed revenue adjustment following a further assessment of the costs and/or expenses incurred, including an assessment of whether these were economically and efficiently incurred. Any such change to the allowed revenue adjustment shall be in writing and shall follow consultation with the licensee and such other persons as the Authority considers desirable.
45. In this condition:
- | | |
|--------------------|--|
| “Contingent Event” | means either: |
| | (a) circumstances under which the licensee has been required by the Secretary of State to increase the size of its security in respect of its Decommissioning Plan to account for the payment of VAT; or |
| | (b) circumstances under which the licensee has been required by the national electricity transmission system operator to undertake |

works, and has undertaken those works, to reduce the impact or likelihood of sub synchronous voltage oscillations on the National Electricity Transmission System, in order to comply with paragraphs 7.13 to 7.23 of the National Electricity Transmission System Security and Quality of Supply Standard version 2.4 (as amended from time to time) and/or Section D, Part 1, paragraph 2.2.6 of the STC (as amended from time to time); or

(c) circumstances under which the licensee has been required to undertake works, and has undertaken those works, to replace all or part of a transformer radiator, and/or Associated Equipment due to a Radiator Fault where:

- (1) the Authority is satisfied that the Radiator Fault is directly caused by the Root Cause or Remedial Works;
- (2) the costs and/or expenses directly incurred or expected to be incurred in connection with the works are not recoverable under the SPA or any other commercial arrangement; and
- (3) the Radiator Fault occurs before the sixth (6th) anniversary of the first date of the Review Period.

“Associated Equipment”

means any equipment on the transmission assets (for the avoidance of doubt, not including the transformer radiators) where the relevant equipment has, by or on behalf of Beatrice Offshore Windfarm Limited, been fitted, modified or altered or (to the extent) affected by works directly required due to a Radiator Fault.

“Decommissioning Plan”

means the plan for the decommissioning of the transmission assets of the licensee as provided to Ofgem under Section 6 of the licensee’s ITT submission for the Beatrice project and reflected in the ITT financial model submitted by the licensee for the Beatrice project.

"Pre-identified Transformer Radiators"	means the transformer radiators defined as "Pre-identified Transformer Radiators" in the SPA, and as marked in the diagram annexed to the SPA at Schedule 14.
"Radiator Fault"	means an oil leak occurring or defect arising in any transformer radiator on the 220kV/33kV transformer, GT1 and GT2, located on the Beatrice Offshore Transformer Module (OTM) 1 or OTM 2, or defect arising in any Associated Equipment, the root cause of which is (i) the same as the Root Cause or (ii) any Remedial Works.
"RCA Report"	has the meaning given to it in the SPA.
"Remedial Works"	means any remedial measures, including repair or replacement works of transformer radiators and any Associated Equipment, implemented in respect of the Root Cause.
"Review Period"	has the meaning given to it in the SPA.
"Root Cause"	means the root cause of the existing failure which has resulted in the oil leaks detected in the Pre-identified Transformer Radiators and as identified in the final RCA Report.
"SPA"	means the sale and purchase agreement dated on or about the date that this licence comes into force between the licensee and Beatrice Offshore Windfarm Limited.

Formula for the Refinancing Gain Share (RFG_i)

Part A: Introduction

46. The refinancing of External Debt in each of the forms described below shall be a "Refinancing" for the purpose of determining a Refinancing Gain Share:
- (a) any amendment, variation, novation, supplement or replacement of any External Debt financing agreement;
 - (b) the exercise of any right, or the grant of any waiver or consent, under any External Debt financing agreement;
 - (c) the disposition of any rights or interests in, or the creation of any rights of participation in respect of, the External Debt financing agreements or the creation or granting of any other form of benefit or interest in either the External Debt financing agreements or the contracts, revenues or assets of the licensee whether by way of security or otherwise; and

- (d) any other arrangement put in place by the licensee or another person which has an effect which is similar to any of (a)-(c) above or which has the effect of limiting the licensee's ability to carry out any of (a)-(c) above.

Part B: Notification of a Qualifying Refinancing

- 47. A Qualifying Refinancing is a Refinancing, other than an Exempt Refinancing, that will give rise to a Refinancing Gain greater than zero.
- 48. Where the licensee intends to undertake a Refinancing that may qualify as a Qualifying Refinancing it shall give written notification of such to the Authority including the terms of the Refinancing, no later than three months prior to when the Refinancing is expected to take place.
- 49. Following receipt of a notification under paragraph 48 the Authority may request additional information including, but not limited to:
 - (a) full details of the terms of the Refinancing, including a copy of the proposed model (based on the Financial Model) relating to it;
 - (b) the proposed value of any financial gain realised from the Refinancing as calculated in accordance with paragraphs 52 to 54 (inclusive) ("Proposed Refinancing Gain") and evidence of how it was calculated;
 - (c) the proposed value of the Refinancing Gain Share (RFG_t) ("Proposed Refinancing Gain Share") as calculated in accordance with paragraph 55 including the relevant year(s) in which it would apply and evidence of how it was calculated; and
 - (d) any other analysis or information, that would assist the Authority to fully assess the Refinancing to which the notice relates;

and the licensee must provide such information within two weeks of the Authority's request.

- 50. If the Authority considers that the analysis or information received under paragraph 48 is insufficient to enable the Authority to determine if the Refinancing will be a Qualifying Refinancing or to determine the value of the Refinancing Gain and the Refinancing Gain Share (RFG_t) or the period(s), if any, over which the Refinancing Gain Share (RFG_t) will apply, the Authority may request any additional information that it considers appropriate. If the Authority requests additional information, the licensee shall give such information to the Authority within one month of the Authority's request.
- 51. For the avoidance of doubt, where a Refinancing will not give rise to a Refinancing Gain greater than zero, the licensee does not need to give written notification of the Refinancing to the Authority under paragraph 48.

Part C: Calculation of the Refinancing Gain and the Refinancing Gain Share (RFG_t)

- 52. The licensee shall calculate the Proposed Refinancing Gain that it must give to the Authority under sub-paragraph 49(b) as an amount equal to the greater of zero and (A - B), where:

A = the Net Present Value of the Distributions to be made to each Relevant Person (without double counting) following the Refinancing projected immediately after the Qualifying Refinancing (taking into account the effect of the Refinancing and using the Financial Model as updated so as to be current immediately prior to the Refinancing);

B = the Net Present Value of the Distributions to be made to each Relevant Person (without double counting) following the Refinancing projected immediately prior to the Refinancing (without taking into account the effect of the Refinancing but using the Financial Model as updated so as to be current immediately prior to the Refinancing).

53. The discount rate used to calculate the Net Present Values A and B for the purposes of paragraph 52, shall be equal to the blended internal rate of return to the Relevant Persons over the expected lifetime of the licence as set out in the Financial Model (“Equity IRR”).
54. For the purposes of paragraph 52, the value of the Refinancing Gain is net of any reasonable and proper breakage costs necessary to facilitate the Qualifying Refinancing together with the reasonable and proper professional costs that the licensee will directly incur in relation to the Qualifying Refinancing (without double counting).
55. The licensee shall calculate the Proposed Refinancing Gain Share (RFG_t) as the amount, which, when summed over the Relevant Years to which it applies, shall represent 50 per cent of the Refinancing Gain realised by the licensee in a Qualifying Refinancing.

Part D: Determination of the Refinancing Gain and the Refinancing Gain Share (RFG_t)

56. Where the Authority determines that the Refinancing is a Qualifying Refinancing, the Authority shall determine, subject to paragraph 57, the value of the Refinancing Gain and the Refinancing Gain Share (RFG_t) and the period(s), if any, over which the Refinancing Gain Share (RFG_t) will apply. The Refinancing Gain and the Refinancing Gain Share (RFG_t) shall be determined in accordance with the principles set out in paragraphs 52 to 55 (inclusive). The Refinancing Gain Share (RFG_t) may be:
 - (a) a lump sum amount, applicable for one Relevant Year; or
 - (b) an ongoing amount applicable over more than one Relevant Year;
57. In relation to the Relevant Year t , the Refinancing Gain and the Refinancing Gain Share Mechanism (RFG_t) shall be:
 - (a) the values determined by the Authority under paragraph 56; or
 - (b) if the Authority has not requested additional information under paragraph 50 and the Authority has not made a determination under paragraph 56 within three months of the date on which the notice was received by the Authority under paragraph 48 and the Refinancing referred to in the notice has taken place, the Proposed Refinancing Gain and the Proposed Refinancing Gain Share given by the licensee to the Authority under paragraph 49; or
 - (c) if the Authority has requested additional information under paragraph 50 and the Authority has not made a determination under paragraph 56 within three months of receiving all additional information requested and the Refinancing referred to in

the notice has taken place, the Proposed Refinancing Gain and the Proposed Refinancing Gain Share given by the licensee to the Authority under paragraph 49; or

- (d) in all other cases, zero, including situations where the Authority receives a notice from the licensee under paragraph 48 but the Refinancing referred to in the notice does not subsequently take place.

Part E: Exemptions to the Refinancing Gain Share (RFG_i)

58. A Refinancing will be exempt for the purposes of determining a Refinancing Gain Share where it is undertaken to remove a licensee from Financial Distress irrespective of whether it will give rise to a Refinancing Gain greater than zero (“Exempt Refinancing”).
59. Where the licensee intends to undertake a Refinancing that may qualify as an Exempt Refinancing it must give written notification to the Authority, and use best endeavours to provide this no later than three months prior to when the Refinancing is expected to take place, detailing:
- (a) full details of the terms of the Exempt Refinancing, including a copy of the proposed model (based on the Financial Model) relating to it; and
- (b) any other analysis or information, that would assist the Authority to determine if the Refinancing is an Exempt Refinancing to which the notice relates.
60. If the Authority considers that the analysis or information provided under paragraph 59 is insufficient to enable it to determine whether the Refinancing is an Exempt Refinancing, the Authority may request any additional information that it considers appropriate. If the Authority requests additional information, the licensee shall give such information to the Authority within one month of the Authority’s request.
61. The Authority shall determine whether the Refinancing detailed in the notice received under paragraph 59 is an Exempt Refinancing, within three months of the later of:
- (a) the date the notice was received by the Authority under paragraph 59; or
- (b) where applicable, the date the Authority received from the licensee all additional information requested under paragraph 60.
62. If the Authority has not made a determination under paragraph 61 within three months of the later of:
- (a) the date the notice was provided to the Authority under paragraph 59; or
- (b) where applicable, the date the Authority received from the licensee all additional information requested under paragraph 60.
- the Refinancing detailed in the notice provided under paragraph 59 shall be deemed to be an Exempt Refinancing.
63. The Authority’s determinations in relation to any notices given under paragraphs 48 or 59 shall be in writing, shall be copied to the licensee and shall be published.

Amended Standard Condition E12–J4: Restriction of Transmission Revenue: Annual Revenue Adjustments

1. The purpose of this condition is to provide for adjustments to Allowed Transmission Owner Revenue (OFTO_t) in relation to the Licensee’s Transmission System performance and this condition shall not take effect until the transmission system to which this licence relates has been transferred to the licensee.
2. For the purposes of paragraph 4 of Amended Standard Condition E12– J2 (Restriction of Transmission Revenue: Revenue from Transmission Owner Services), the performance availability revenue adjustment term (PA_t) is derived from the following formula:

$$PA_t = AI_t + ICA_t \tag{9}$$

where:

AI_t means the Transmission System Availability Incentive, whether of a positive or of a negative value, as derived from the formula set out in paragraph 6;

ICA_t means the Incremental Capacity Incentive Adjustment term as derived from the formula set out in paragraph 18.

Part A: Transmission System Availability Incentive

3. The licensee shall, in providing Transmission Owner Services, use reasonable endeavours to make its transmission system available to the System Operator in accordance with Standard Condition E15 (Obligation to provide transmission services) and Good Industry Practice to minimise the effect and duration of any Transmission Service Reduction.
4. Where a Transmission Service Reduction applies to a part of the Licensee’s Transmission System and the licensee reasonably expects that the duration of such a Transmission Service Reduction will apply for a period of more than 21 days then the licensee shall within 7 days of the Transmission Service Reduction occurring notify the Authority in writing of the Transmission Service Reduction including:
 - (a) details of the Transmission Service Reduction on the Transmission Services the licensee provides to the System Operator;
 - (b) the cause of the Transmission Service Reduction and whether, in the licensee’s opinion, the Transmission Service Reduction has been caused (in whole or in part) by an Exceptional Event;
 - (c) any interim work or other actions which are being undertaken to minimise the effect of the Transmission Service Reduction; and
 - (d) indicate the timescale in which the licensee reasonably considers that the Transmission Service Reduction will be resolved together with supporting information that shall include (without limitation) any Service Restoration Proposal agreed with the System Operator in accordance with the STC.

5. Where, in the Incentive Period y , the total effect and duration of all Transmission Service Reductions, excluding those caused (in whole or in part) by an Exceptional Event:
- (a) results in transmission system availability being, on average, below 80 per cent in that incentive period; or
 - (b) results in transmission system availability being, on average, below 85 per cent when considering the 24 month period of the Incentive Period y and the Incentive Period $y-1$;

then the licensee shall provide a written statement to the Authority, from an authorised director of the licensee, within three months of the end of Incentive Period y , explaining how the steps the licensee has taken have discharged the obligations in paragraph 3.

6. For the purposes of paragraph 2, the term AI_t is derived from the following formula for all Relevant Years:

$$AI_t = (BR_{t-1} + ICA_{t-1}) \times AF_y \quad (10)$$

where $y = t$

except in cases where Asset Transfer occurs between 1st January and 31st March (inclusive), where:

$$\text{in Relevant Year } t = 2, AI_2 = 0; \text{ and} \quad (11)$$

in Relevant Year $t = 26$ it is derived from the following formula:

$$AI_{26} = \left(\frac{BR_{24}}{PR_{24}} \times PR_1 \right) \times AF_{26} \quad (12)$$

where:

BR_t means the Base Transmission Revenue calculated in accordance with the formula specified in paragraph 4 of Amended Standard Condition E12–J2 (Restriction of Transmission Revenue: Revenue from Transmission Owner Services); and

PR_t means the proportion of revenue calculated in accordance with the formula specified in paragraph 4 of Amended Standard Condition E12–J2 (Restriction of Transmission Revenue: Revenue from Transmission Owner Services); and

ICA_t means the Incremental Capacity Incentive Adjustment term calculated in accordance with the formula specified in paragraph 18 of Amended Standard Condition E12–J4 (Restriction of Transmission Revenue: Annual Revenue Adjustments); and

AF_y means the transmission system availability factor, which in any Relevant Year before the Commencement Relevant Year shall take the value zero and in each subsequent Relevant Year is the revenue adjustment factor based on the licensee's performance against the transmission system

availability incentive during Incentive Period y . This converts percentage unavailability to percentage revenue impact, and is derived from the following formula:

$$AF_y = (CCAP_y - PO_y) \times \frac{RCAP}{PCAP_y} \quad (13)$$

where:

$CCAP_y$ means the annual credit availability cap. This is the maximum unavailability of the system in percentage terms that can cause a positive impact on Base Transmission Revenue (BR_t) in any given year. This is calculated for all incentive periods as:

$$CCAP_y = 2\% \times PR_{t-1} \quad (14)$$

where $t = y$

except in cases where Asset Transfer occurs between 1st January and 31st March (inclusive), where in Incentive Period $y=26$ it is derived from the following formula:

$$CCAP_y = 2\% \times PR_1 \quad (15)$$

PO_y means the paid out unavailability. This is the total unavailability in Incentive Period y that affects the Allowed Transmission Owner Revenue in Relevant Year t and is calculated as:

$$PO_y = \text{minimum} \begin{cases} CCAP_y + PCAP_y \\ BF_y + AU_y \end{cases} \quad (16)$$

where:

BF_y means the brought forward unavailability which takes the value of zero in the first year. In subsequent years, it is calculated in accordance with the formula below

$$BF_y = CF_{y-1} \quad (17)$$

where:

CF_y means the carried forward unavailability. This is the total unavailability earned in previous years but not yet paid out and is calculated as:

$$CF_y = AU_y + BF_y - PO_y \quad (18)$$

$RCAP$ means the annual revenue impact cap. This is set at 10 per cent.

$PCAP_y$ means the annual penalty availability cap. This is the maximum unavailability of the system below the Target Availability in percentage point terms that can cause a negative impact on

Allowed Transmission Owner Revenue in any given year. This is calculated for all incentive periods as

$$PCAP_y = 4\% \times PR_{t-1} \quad (19)$$

where $t = y$

except in cases where Asset Transfer occurs between 1st January and 31st March (inclusive), where in Incentive Period $y = 26$ it is derived from the following formula:

$$PCAP_{26} = 4\% \times PR_1 \quad (20)$$

7. For the purposes of paragraph 6, the accrued unavailability (AU_y) shall be calculated in accordance with the following formula:

$$AU_y = \text{minimum} \begin{cases} TCAP_y - BF_y \\ TU_y \end{cases} \quad (21)$$

where:

$TCAP_y$ means the total unavailability cap in percentage terms. This is the total annual unavailability that can affect Allowed Transmission Owner Revenue over five years. This is calculated as:

$$TCAP_y = CCAP_y + \sum_y^{y+4} PCAP_y \quad (22)$$

TU_y means the total unavailability of the Licensee's Transmission System in Incentive Period y in percentage terms and is calculated as:

$$TU_y = \frac{WU_y}{MA_y} \quad (23)$$

where:

MA_y is the maximum seasonally weighted annual availability in megawatt hours (MWh) and is calculated as:

$$MA_y = \sum_{i=1}^{12} (TC_{i,y} \times W_{i,y}) \quad (24)$$

where:

$TC_{i,y}$ means the maximum transmission system availability in month i of Incentive Period y that is required to be delivered being the minimum of:

- (i) the aggregate Transmission Entry Capacity; and
- (ii) the maximum system availability in month i of Incentive Period y that is capable of being delivered by the licensee by providing Transmission Services to the Normal Capability Limits;

both expressed as number of MWh that could be achieved if the available capacity were fully

utilised.

$W_{i,y}$ is the monthly seasonal weighting term, expressed in percentage terms, the monthly values of which are given as performance incentive parameters in Annex A of Amended Standard Condition E12–J4 (Restriction of Transmission Revenue: Annual Revenue Adjustments)

WU_y means the weighted annual unavailability expressed in MWh and is calculated as:

$$WU_y = \sum_{i=1}^{12} MWU_{i,y} \quad (25)$$

where:

$MWU_{i,y}$ means the monthly weighted unavailability and is calculated as:

$$MWU_{i,y} = RWU_{i,y} \times W_{i,y} \quad (26)$$

where:

$RWU_{i,y}$ is the monthly capacity weighted unavailability in MWh and is calculated as:

$$RWU_{i,y} = \sum_x WEO_{x,i} \quad (27)$$

where:

$WEO_{x,i}$ means the weighted energy Outage in MWh of a specific Transmission Service Reduction, x, in month i of Incentive Period y and is calculated as:

$$WEO_{x,i} = WCR_{x,i} \times D_{x,i} \times \text{minimum} \begin{cases} TEC \\ NCL \end{cases} \quad (28)$$

where:

$WCR_{x,i}$ means the weighted capacity reduction in MWh of a specific Transmission Service Reduction, x, in month i of Incentive Period y and is calculated as:

$$WCR_{x,i} = a(C_{x,i})^b \quad (29)$$

where:

- a shall be 1 in this licence.
- $C_{x,i}$ is the capacity of the Outage measured as a percentage of the capacity that could not be delivered relative to the minimum of:
- (i) the aggregate Transmission Entry Capacity; and
 - (ii) the Normal Capability Limits;
- both expressed as number of MW that could be achieved if the available capacity were fully utilised.
- b shall be 1.3 in this licence
- $D_{x,i}$ means the duration in hours of a specific Transmission Service Reduction, x, in month i of Incentive Period y
- TEC means the Transmission Entry Capacity
- NCL means the Normal Capability Limits.

8. For the purposes of this Amended Standard Condition, any Transmission Service Reduction (calculated as $C_{x,i} \times D_{x,i} \times \text{minimum}(\text{TEC}, \text{NCL})$) shall be excluded from the calculation of the Transmission System Availability Incentive (AI_t) in the following circumstances:
- (a) any reduction in transmission system availability resulting from a de-energisation or disconnection of a user's equipment under an event of default as defined in the CUSC;
 - (b) any reduction in transmission system availability resulting from a user's request for disconnection in accordance with the Grid Code;
 - (c) any reduction in transmission system availability resulting from emergency de-energisation by a user as defined in the CUSC;
 - (d) any reduction in transmission system availability resulting from an emergency de-energisation or disconnection of a user's equipment necessary to ensure compliance with the Electricity Safety, Quality and Continuity Regulations 2002, as amended from time to time, or to otherwise ensure public safety;
 - (e) any reduction in transmission system availability, subject to sub-paragraphs i to iii of this paragraph 8(e) and the licensee ensuring compliance with paragraph 3, which in the opinion of the Authority is solely as a result of an event or circumstance under which the licensee has been required by the national electricity transmission system operator to take action to reduce the impact or likelihood of sub synchronous voltage oscillations on the National Electricity Transmission System in order to comply with paragraphs 7.13 to 7.23 and 9.1 of the National Electricity Transmission System Security and Quality of Supply Standard version 2.4 (as amended from time to time) and/or Section D, Part 1, paragraph 2.2.6 of the STC (as amended from time to time), where:

- i. the licensee has provided details of the reduction in system availability within 14 days of its occurrence;
 - ii. the licensee has provided such further information and/or analysis as the Authority may require; and
 - iii. the Authority directs the extent of the exclusion from reported system incentive performance in accordance with paragraph 10; and
- (f) any reduction in transmission system availability during the Relevant Period, subject to sub-paragraphs i to iv of this paragraph 8(f) and the licensee ensuring compliance with paragraph 3, which in the opinion of the Authority is solely as a result of works undertaken by the licensee to replace all or part of a transformer radiator and/or any Associated Equipment due to a Radiator Fault, where:
 - i. the loss of revenue associated with the reduction of transmission system availability is not recoverable under the SPA or any other commercial arrangement;
 - ii. the licensee has provided details of the reduction in system availability within 14 days of its occurrence;
 - iii. the licensee has provided such further information and/or analysis as the Authority may require; and
 - iv. the Authority directs the extent of the exclusion from reported system incentive performance in accordance with paragraph 10.
- 9. The Authority shall, by written notice to the licensee, direct that, for the purpose of calculating the monthly capacity weighted unavailability ($RWU_{i,y}$) the value of the monthly capacity weighted unavailability ($RWU_{i,y}$) shall be adjusted to the extent specified in that direction to offset the impact of an Exceptional Event, where:
 - (a) the licensee considers that any event on the Licensee's Transmission System that causes a Transmission Service Reduction has been wholly or partially caused by an Exceptional Event;
 - (b) the licensee has notified the Authority of such an event within 14 days of its occurrence;
 - (c) the licensee has provided details of the reduction in system availability that the licensee considers resulted from the Exceptional Event (including the anticipated duration of any reduction in availability) and such further information, if any, as the Authority may require in relation to such an Exceptional Event; and
 - (d) the Authority is satisfied that the event notified to it under sub-paragraph (b) is an Exceptional Event
- 10. For the purposes of paragraph 8(e)(iii), paragraph 8(f)(iv) and paragraph 9, the adjustment directed by the Authority shall be based on the extent to which the Authority is satisfied that the licensee had taken reasonable steps, consistent with Good Industry Practice, to manage the impact of the event or circumstance on the availability of services provided to the System Operator in accordance with Standard Condition

E15 (Obligation to provide transmission services) (both in anticipation of the event and after the event has occurred).

11. A direction under paragraph 9 shall not have effect unless, before it is made, the Authority has given notice to the licensee:
 - (a) setting out the terms of the proposed direction, including the extent to which the value of the monthly capacity weighted unavailability ($RWU_{i,y}$) for month i , and each subsequent month, should be decreased to offset the impact of the Exceptional Event;
 - (b) stating the reasons, having regard to the information provided by the licensee and Good Industry Practice, why it proposes to issue the direction; and
 - (c) specifying the period (not being less than 14 days from the date of the notice) within which the licensee may make representations or objectionsand the Authority has considered such representations or objections and given reasons for its decision.
12. The licensee may request that a direction issued by the Authority pursuant to paragraph 9 be modified, where the licensee considers that:
 - (a) there has been a material change to the information previously provided by the licensee in relation to the Exceptional Event specified in the previous direction; and
 - (b) it has notified the Authority of the material change, no later than 3 months after the end of the incentive period to which it relates.

Part B: Transmission System Availability Incentive: Supplementary Provisions

13. The licensee shall, by no later than 14 days after the end of each three month period (being the three months ending either 31 March, 30 June, 30 September and 31 December), submit to the Authority a report setting out the monthly capacity weighted unavailability ($RWU_{i,y}$) for each of the months within the three month period and the report should include the calculation of $RWU_{i,y}$ and provide a commentary in relation to those months where monthly availability ($TC_{i,y} - \sum_x (C_{x,i} \times D_{x,i} \times \text{minimum}(TEC, NCL))$) has fallen below the monthly incentive target (Target Availability $\times TC_{i,y}$).
14. The licensee shall, by no later than nineteen (19) years after this condition comes into force, procure, to the satisfaction of the Authority, Financial Security for the purposes of covering future financial liabilities up to and including the Closing Relevant Year.
15. For the purposes of paragraph 14, the licensee shall, by no later than three (3) months before the date that is nineteen (19) years after this condition comes into force, provide to the Authority a notice specifying:
 - (a) the amount of Financial Security that the licensee intends to procure, being no less than 50 per cent of Base Transmission Revenue (BR_t);
 - (b) the form of the Financial Security that the licensee intends to procure;
 - (c) the independent financial institution with which the Financial Security is to be lodged which must, unless the Authority consents otherwise, hold a credit rating

- equivalent to at least an “A-” with a credit rating agency recognised by Ofgem and reside in a country with a credit rating of at least “A”; and
- (d) the detailed terms on which the security can be called upon to meet the financial liabilities in respect of the Transmission System Availability Incentive (AI_t).
16. For the avoidance of doubt, the amount of Financial Security procured under paragraph 15(a) shall be:
- (a) for Relevant Year t=20 (by no later than nineteen (19) years after this condition comes into force), no less than 0.5 x BR₂₀
- (b) for Relevant Year t=21, no less than 0.5 x BR₂₁
- (c) for Relevant Year t=22, no less than 0.5 x BR₂₂
- (d) for Relevant Year t=23, no less than 0.5 x BR₂₃
- (e) for Relevant Year t=24, no less than 0.5 x BR₂₄ /PR₂₄
17. The Authority shall, within two (2) months of receiving the notice specified in paragraph 15, indicate to the licensee whether the proposed arrangements for Financial Security (as specified in the notice) would be satisfactory. Where the Authority considers that the Financial Security arrangements proposed by the licensee are not satisfactory, the Authority shall set out in writing to the licensee the reasons why the proposed Financial Security arrangements are not satisfactory and those areas where modifications would be required. The Authority shall also set out the timescales within which the licensee is required to provide its amended proposal.

Part C: Incremental Capacity Incentive Adjustment

18. For the purposes of paragraph 2, the Incremental Capacity Incentive Adjustment term (ICA_t) is derived from the following formula:

$$ICA_t = ACA_t \times RIT_t \tag{30}$$

where:

ACA_t means the additional capacity investment adjustment, which for the purposes of this licence shall take the value zero, but may be changed in accordance with paragraph 19.

RIT_t means the revenue indexation adjustment term calculated in accordance with the formula specified in paragraph 4 of Amended Standard Condition E12–J2 (Restriction of Transmission Revenue: Revenue from Transmission Owner Services).

19. For the purposes of paragraph 18, the additional capacity investment adjustment term (ACA_t) shall be determined by the Authority in accordance with paragraphs 20 to 22 and shall otherwise take the value zero.
20. Where the licensee has entered into an agreement with the System Operator in accordance with Standard Condition E17 (Obligations in relation to offers for connection etc) to provide additional capacity it shall:
- (a) submit a notice in writing to the Authority, together with supporting evidence, setting out the revenue adjustment that it considers is required to remunerate the

- costs that it will incur in providing that additional capacity, which shall include (without limitation):
- (i) the amount of additional capacity that the licensee is contractually required to make available to the System Operator;
 - (ii) the capital costs that it expects to incur in providing the additional capacity, demonstrating that such costs are not more than 20 per cent of the original investment cost incurred by the licensee in respect of the Licensee's Transmission System in the Commencement Relevant Year;
 - (iii) the anticipated additional costs of operation and maintenance that are expected to be incurred as a consequence of providing the additional capacity; and
 - (iv) the costs of financing the additional investment in the Licensee's Transmission System.
- (b) provide such additional information as the Authority may require to make a determination of the appropriate revenue adjustment in accordance with paragraph 22.
21. A notice referred to in paragraph 20 shall be given as soon as is reasonably practicable after the licensee has entered an agreement with the System Operator in accordance with Standard Condition E17 (Obligations in relation to offers for connection etc), and, in any case, not later than three (3) months after the end of the Relevant Year in which it occurs.
22. The Authority shall determine :
- (a) the revenue adjustment (ACA_t) that would be required to remunerate the efficient costs that the Authority considers to have been reasonably incurred by the licensee;
 - (b) the Relevant Year from which the revenue adjustment shall apply.
23. For the purposes of paragraph 22, in determining an appropriate adjustment:
- (a) the Authority may request that the licensee provide such information that it reasonably requires for the purposes of making its determination. The licensee is required to provide such information within the timescales set out by the Authority;
 - (b) the Authority shall, following consultation with interested parties, notify the licensee in writing of its proposed determination of the additional capacity investment adjustment (ACA_t);
 - (c) the licensee, shall have 28 days within which to make representations to the Authority's proposed determination that has been notified to it pursuant to sub-paragraph (b);
 - (d) the Authority, having regard to any representations made by the licensee and not withdrawn, shall propose a modification to the ACA_t pursuant to sections 11A to 11F of the Act. The proposed modification shall only take effect where made by the Authority in accordance with sections 11A to 11F of the Act.
24. In this condition:

“Relevant Period”	means before the sixth (6 th) anniversary of the first date of the Review Period.
“Associated Equipment”	each has the meaning given to it at paragraph 45 of Amended Standard Condition E12-J3.
“Radiator Faults”	
“Review Period”	
“Root Cause”, and	
“SPA”	

ANNEX A to Amended Standard Condition E12–J4 (Restriction of Transmission Revenue: Annual Revenue Adjustments)

Performance incentive parameters

1. For the purposes of paragraph 7, the performance incentive parameters are set out in the table below:

Month i	Jan(i=1)	Feb (i=2)	Mar (i=3)	Apr (i=4)	May (i=5)	Jun (i=6)
$W_{i,y}$	118.40%	118.30%	107.20%	97.50%	83.60%	79.50%
Month i	Jul (i=7)	Aug (i=8)	Sept (i=9)	Oct (i=10)	Nov (i=11)	Dec (i=12)
$W_{i,y}$	74.10%	80.80%	95.70%	113.60%	116.30%	115.00%

**Amended Standard Condition E12–J5: Restriction of Transmission Revenue:
Adjustments**

1. The purpose of this condition is to set out the licensee's obligations should its Regulated Transmission Revenue (AR_t) differ from its Allowed Transmission Owner Revenue ($OFTO_t$) to the extent set out below.
2. If, in respect of any Relevant Year t , the licensee's Regulated Transmission Revenue (AR_t) in that Relevant Year exceeds 103 per cent of Allowed Transmission Owner Revenue ($OFTO_t$) for that Relevant Year, the licensee:
 - (a) shall provide a written explanation for that event to the Authority by 31 July in the associated Relevant Year $t+1$; and

shall not increase its charges for the provision of Transmission Services for Relevant Year $t+2$ unless it has demonstrated to the reasonable satisfaction of the Authority that the Regulated Transmission Revenue (AR_t) in that next following Relevant Year would not be likely to exceed the Allowed Transmission Owner Revenue ($OFTO_t$) in that same Relevant Year.
3. If, in respect of two successive Relevant Years t and $t+1$, the licensee's Regulated Transmission Revenue (AR_t) in each of those Relevant Years exceeds 104 per cent of Allowed Transmission Owner Revenue ($OFTO_t$) for those Relevant Years, the licensee:
 - (b) shall provide a written explanation for that event to the Authority by 31 July in the associated Relevant Year $t+2$; and

shall, if required by the Authority, adjust its charges for the provision of Transmission Services, such that the Regulated Transmission Revenue (AR_t) would not be likely, in the judgment of the Authority, to exceed the Allowed Transmission Owner Revenue ($OFTO_t$) in Relevant Year $t+3$.
4. If, in respect of any Relevant Year t , the licensee's Regulated Transmission Revenue (AR_t) is less than 97 per cent of the Allowed Transmission Owner Revenue ($OFTO_t$) for that Relevant Year, the licensee must provide a written explanation for that event to the Authority by 31 July in the associated Relevant Year $t+1$.

Amended Standard Condition E12–J6: Provision of Information to the System Operator

1. The purpose of this condition is to set out when the licensee shall provide estimates of its Allowed Transmission Owner Revenue (OFTO_t) to the System Operator and the Authority.
2. In the Commencement Relevant Year, the licensee shall, as soon as reasonably practicable,
 - (a) notify the System Operator of its best estimate for the value of OFTO_t in respect of the Commencement Relevant Year; and
 - (b) notify the System Operator of its best estimate for the value of OFTO_{t+1};where:

OFTO_t means the Allowed Transmission Owner Revenue in the Relevant Year t calculated in accordance with Amended Standard Condition E12–J2 (Restriction of Transmission Revenue: Revenue from Transmission Owner Services).
3. In each Relevant Year subsequent to the Commencement Relevant Year, the licensee shall, on or before 1 November (or such later date as the Authority may direct),
 - (a) notify the System Operator of its latest best estimate for the value of OFTO_t; and
 - (b) notify the System Operator of its latest best estimate for the value of OFTO_{t+1}.
4. The licensee shall, at all times, keep under review the estimates notified to the System Operator pursuant to paragraphs 2 or 3. If at any time, the licensee reasonably considers that the values of OFTO_t and/or OFTO_{t+1}, notified to the System Operator will be significantly different from the estimates previously notified to the System Operator, the licensee shall notify the System Operator of the revised values for OFTO_t and/or OFTO_{t+1} as soon as reasonably practicable.
5. In each Relevant Year subsequent to the Commencement Relevant Year, the licensee shall, by 30 June (or such later date as the Authority may direct), provide a statement to the Authority showing:
 - (a) the values of OFTO_t and OFTO_{t+1} notified to the System Operator in the Relevant Year t-1 in accordance with paragraph 2 or paragraph 3 of this condition; and
 - (b) any revised values of OFTO_t and OFTO_{t+1} notified to the System Operator in the Relevant Year t-1 in accordance with paragraph 4 of this condition.

Amended Standard Condition E12–J7: Duration of the Revenue Restriction Provisions

1. The purpose of this condition is to enable the licensee to make a formal request for the disapplication of the Charge Restriction Conditions (in whole or in part) and for such provisions to be disappplied following such a request in the circumstances specified below.

Part A: Conditions are to continue subject to disapplication

2. The Charge Restriction Conditions shall apply for as long as this licence continues in force, but shall cease to have effect (in whole or in part, as the case may be) if the licensee delivers to the Authority a Disapplication Request in accordance with the provisions of Part B and C below and:
 - (c) the Authority agrees in writing to the Disapplication Request; or
the application of the Charge Restriction Conditions (in whole or in part) is terminated by notice given by the licensee in accordance with the provisions of Part D below.

Part B: Procedure for making a Disapplication Request

3. The licensee may ask the Authority to consent to the disapplication of the Charge Restriction Conditions (in whole or in part) by serving a Disapplication Request on the Authority under this condition.
4. A Disapplication Request pursuant to this condition shall:
 - (d) be in writing and addressed to the Authority;
specify those of the Charge Restriction Conditions (or any part or parts of them) to which the request relates;
provide a full statement of the licensee’s reasons for making the request;
contain such other information that would enable the Authority to fully assess the Disapplication Request; and
state the date (which must not be earlier than the appropriate date that is mentioned in Part C below) from which the licensee wishes the Authority to agree that the specified Charge Restriction Conditions (or part or parts of them) shall cease to have effect (the “Disapplication Date”).
5. If, within 28 days of the receipt of a Disapplication Request, the Authority gives notice to the licensee:
 - (e) specifying further information that it reasonably considers is required in order to fully assess the Disapplication Request, and
requests the licensee to provide that information,
the Disapplication Request shall be treated for the purposes of paragraph 2 of this condition as not delivered to the Authority until that further information is provided to the Authority and if, as a consequence, the Disapplication Date set out in the Disapplication Request no longer complies with paragraph 7 below, the

Disapplication Date shall be treated as being the earliest date that would comply with that paragraph.

6. The licensee may withdraw a Disapplication Request at any time.

Part C: Date from which a disapplication may take effect

7. Except where the Authority agrees otherwise, no disapplication following delivery of a Disapplication Request pursuant to this condition shall have effect earlier than the date which is the later of:
 - (a) a date being not less than 12 months after delivery of the Disapplication Request; and
 - (b) the closing date, being not less than 23 calendar years after the date of grant of this Transmission Licence.

Part D: Licensee's right to terminate under a Disapplication Request

8. If the licensee has delivered to the Authority a Disapplication Request that complies with the requirements of Parts B and C of this condition, it may subsequently give the Authority a notice (a "Disapplication Notice") that terminates the application of some or all of the provisions of this Licence specified in that request:
 - (f) in the circumstance described in paragraph 9 of this condition; or
 - (g) in the circumstance described in paragraph 10 of this condition,but in either case the Disapplication Notice may not take effect before the Disapplication Date or such earlier date to which the Authority may have consented under Part C of this condition.
9. The circumstance referred to in paragraph 8(a) above is that by the beginning of the period of 6 months that would end on the Disapplication Date, the Authority has not in response to the Disapplication Request published a decision under section 11A(7) of the Act relating to the modification of:
 - (h) the Charge Restriction Conditions (in whole or in part) to which the Disapplication Request applies; or
 - (i) this condition so as to remove the licensee's right to give the Authority a Disapplication Notice under this condition in respect of the relevant Disapplication Request.
10. The circumstance referred to in paragraph 8(b) above is that the Authority has published a decision under section 11A(7) of the Act as described in paragraph 9(a) or 9(b) and:
 - (j) the licensee has exercised its right to appeal to the Competition Commission against that decision of the Authority as provided for by section 11C of the Act;

the Competition Commission, acting under section 11F of the Act, has, in respect of the provision to which the Disapplication Notice relates: (i) quashed the Authority's decision and (ii) neither remitted the matter back to the Authority

under section 11F(2)(b) of the Act nor substituted its own decision for that of the Authority's under section 11F(2)(c) of the Act; and

no more than 30 days have elapsed since the date on which the Competition Commission quashed the decision in the circumstances described in paragraph 10(b) above.

Amended Standard Condition E12–J8: Allowances in respect of Security Costs

1. The purpose of this condition is to set out the process for the licensee to recover Allowed Security Costs in the event of a Security Period.
2. At any time during a Security Period, the licensee may give notice in writing to the Authority suspending, with effect from the date of receipt of the notice by the Authority, application of such of the Charge Restriction Conditions as may be specified in the notice, for the remaining duration of the Security Period.
3. At any time during a Security Period, the Authority may (having regard to its duties under the Act) by means of directions:
 - (a) suspend or modify for the remaining duration of the Security Period the Charge Restriction Conditions or any part or parts thereof; or
 - (b) introduce for the remaining duration of the Security Period new Charge Restriction Conditions;

in either case, so as to make such provision as in the opinion of the Authority is necessary or appropriate to enable the licensee to recover by means of an appropriate equitable increase in the charges made in the course of the licence an amount estimated as being equal to the licensee's Allowed Security Costs during such period. The licensee shall comply with the terms of any directions so issued.
4. Subject to paragraphs 5 and 7, the licensee is entitled in any Relevant Year to recover an aggregate amount equal to its Allowed Security Costs in that year or (in so far as not previously recovered) any previous year, by means of appropriate equitable increases in the charges made by the licensee in the course of the Transmission Business.
5. Paragraph 4 shall not apply in so far as such allowed security costs:
 - (a) were otherwise recovered by the licensee; or
 - (b) were taken into account by the Authority in setting the Charge Restriction Conditions by means of directions issued under paragraph 3.
6. The licensee shall following the end of each Relevant Year provide to the Authority details in respect of that Relevant Year of:
 - (a) the aggregate amounts charged under paragraph 4 on account of the licensee's Allowed Security Costs; and
 - (b) the basis and calculation underlying the increases in charges made by the licensee in the course of the Transmission Business.
7. Where the Authority is satisfied that the licensee has recovered amounts in excess of the licensee's Allowed Security Costs, the Authority may issue directions requiring the licensee to take such steps as may be specified to reimburse customers of the licensee for the excess amounts charged to them, and the licensee shall comply with any directions so issued.
8. No amounts charged by the licensee under this condition (whether or not subsequently required to be reimbursed) shall be taken into account for the purpose of applying the

charge restriction provisions of Amended Standard Condition E12–J2 (Restriction of Transmission Revenue: Revenue from Transmission Owner Services).

Amended Standard Condition E12–J9: Basis of Transmission Owner Charges

1. The purpose of this condition is to detail the process for the licensee to prepare and submit to the Authority for approval, a statement setting out its basis for Transmission Owner Charges. The Authority only approves the basis upon which the charges for the purposes set out in paragraph 2 below are made.
2. The licensee shall as soon as practicable during the Commencement Relevant Year and, in any case, not later than such date as the Authority shall specify, prepare and submit to the Authority a statement in a form approved by the Authority setting out the basis upon which charges will be made by the licensee:
 - (a) for Transmission Owner Services;
 - (b) for connection to the Licensee's Transmission System, such statement to be in such form and to contain such detail as necessary to enable the System Operator to make a reasonable estimate of the charges for which it would become liable for the provision of such services, and (without prejudice to the foregoing) including the information set out in paragraph 3 as is required by such paragraph to be included in the relevant statement; and
 - (c) for Outage Changes.
3. The statement referred to in paragraph 2 shall in respect of connections to the Licensee's Transmission System include:
 - (a) a schedule listing those items (including the carrying out of works and the provision and installation of electric lines or electrical plant or meters) of significant cost liable to be required for the purpose of connection (at entry or exit points) to the Licensee's Transmission System and for which site specific charges may be made or levied, and including (where practicable) indicative charges for each such item and, in other cases, an explanation of the methods by which and the principles on which such charges will be calculated;
 - (b) the methods by which and the principles on which site specific charges will be made in circumstances where the electric lines or electrical plant to be installed are (at the licensee's discretion) of greater size or capacity than that required;
 - (c) the methods by which and the principles on which any charges (including any capitalised charge) will be made for required maintenance, replacement and repair of electric lines, electrical plant or meters provided and installed for making a connection to the Licensee's Transmission System;
 - (d) the methods by which and the principles on which any charges will be made for disconnection from the Licensee's Transmission System and the removal of electrical plant, electric lines and ancillary meters following disconnection; and
 - (e) such other matters as shall be specified in directions issued by the Authority from time to time for the purpose of this condition.
4. Site specific charges for those items referred to in paragraph 3 shall be set at a level which will enable the licensee to recover:

- (a) the appropriate proportion of the costs directly or indirectly incurred in carrying out any works, the extension or reinforcement of the Licensee's Transmission System and the provision and installation, maintenance, replacement and repair or (as the case may be) removal following disconnection of any electric lines, electrical plant, meters or other items; and
 - (b) a reasonable rate of return on the capital represented by such costs.
- 5. In addition to, and without prejudice to, the licensee's obligations under paragraph 2, the licensee shall, upon being directed to do so by the Authority and within such period as shall be specified in the directions, prepare and submit to the Authority a statement or statements in a form approved by the Authority stating that charges:
 - (a) for Transmission Owner Services;
 - (b) for connection to the Licensee's Transmission System; and
 - (c) for Outage Changeswill be made on such basis as shall be specified in the directions. The statement or statements shall be in such form and contain such detail as necessary to enable the System Operator to make a reasonable estimate of the charges to which it would become liable for the provision of such services. Without prejudice to the foregoing, the statement(s) shall include the information specified in the directions.
- 6. Each statement prepared in accordance with paragraph 5 shall, with effect from the date on which it is approved by the Authority or such later date as the Authority shall specify, replace the corresponding statement prepared by the licensee in accordance with paragraphs 2 or 5 (as from time to time revised in accordance with paragraph 7) which is in force at such date. The licensee shall, with effect from such date make charges in accordance with the statement which has replaced the corresponding statement.
- 7. The licensee may periodically revise the statements in accordance with paragraphs 2 and 5 and shall, at least once in every year this licence is in force, make any necessary revisions to such statements in order that the information set out in the statements shall continue to be accurate in all material respects.
- 8. The licensee shall send a copy of the statements prepared in accordance with paragraphs 2 and 5, and of each revision of such statements prepared in accordance with paragraph 7, to the Authority, and shall publish any such statement on its website.

Amended Standard Condition E12–J10: Excluded Services

Part A: Introduction

1. The purpose of this condition is to set out the basis on which certain services provided by the licensee may be treated as Excluded Services under the Amended Standard Conditions.
2. Excluded Services are services that conform with the General Principle set out at Part C below and that include, without limitation, those services listed at paragraph 9.
3. Revenue derived by the licensee from the provision of Excluded Services is excluded from the calculation of the Allowed Transmission Owner Revenue (OFTO_t) formula.

Part B: Structure of this condition

4. Part C of this condition sets out the General Principle that applies for the purpose of determining which of the services provided by the licensee are to be treated as Excluded Services.
5. Part D of this condition sets out, without limitation, certain categories of services provided by the licensee that are to be treated as Excluded Services.
6. Part E of this condition provides for the Authority to give directions in respect of services provided by the licensee that are to be treated as Excluded Services. It also provides for the Authority to direct that any service provided by the licensee should not be treated as an Excluded Service.

Part C: Statement of General Principle

7. The General Principle is that a service provided by the licensee as part of its Transmission Business is to be treated as an Excluded Service if and to the extent that the service is not already remunerated for under:
 - (a) charges for Transmission Owner Services in accordance with Amended Standard Condition E12-J9 (Basis of Transmission Owner Charges); or
 - (b) charges arising from any activity carried out under the Network Innovation Competition which results in Returned Royalty Income.
8. The services referred to in paragraph 7(a) include (without prejudice to the foregoing):
 - (a) the making available of Transmission Owner Services;
 - (b) the carrying out of works for the installation of electric lines or electrical plant for the purpose of maintaining or upgrading the Licensee's Transmission System (not otherwise payable in respect of connections to the Licensee's Transmission System);
 - (c) the carrying out of works or the provision of maintenance or repair in relation to the Licensee's Transmission System for the purpose of enabling the licensee to comply with Amended Standard Condition E13 (System Operator – Transmission Owner Code) and Standard Condition E16 (Transmission system security standard and quality of service), the Electricity Safety, Quality and Continuity Regulations 2002

or any regulations made under section 29 of the Act or any other enactment relating to safety or standards applicable in respect of the Transmission Business; and

- (d) the provision, installation and maintenance of any meters, switchgear or other electrical plant ancillary to the licensee's provision of Transmission Owner Services.

Part D: Categories of Excluded Services

- 9. Subject to Part D of this condition, Excluded Services will include, but are not limited to, the following services:

ES1. Connection services: The whole or an appropriate proportion (as the case may be) of the charges of the type described in Amended Standard Condition E12-J9 (Basis of Transmission Owner Charges) and borne by any person as connection charges in respect of connections made after the grant of this licence, (but only to the extent that the service is not already remunerated under one of the charges set out at paragraph 7 of this condition).

ES2. Diversionary works under an obligation: This category consists of the relocating of any electric line or electrical plant (including the carrying out of any associated works) pursuant to any statutory obligation other than one imposed on the licensee under section 9(2) (General duties of licence holders) of the Act, where the statutory obligation makes provision for the reimbursement of the costs incurred.

ES3. Outage Changes: The net costs reasonably incurred by the licensee as a result of any Outage Change declared to the System Operator and which are agreed by the System Operator. Where there is a failure to agree the costs payable to the licensee, they may be determined by the Authority following the provision by the licensee of such information as the Authority may reasonably request. Any revenues received by the licensee from the System Operator in respect of a Non-Chargeable Outage Change shall not be regarded as Excluded Service revenues under this condition.

ES4. NIC payments made by the System Operator to the licensee in respect of NIC funding in accordance with Amended Standard Condition E12-J11 (The Network Innovation Competition).

ES5. Miscellaneous. With the approval of the Authority, the provision of any other service that:

- (a) is for the specific benefit of any third party who requests it; and
- (b) is not made available by the licensee as a normal part of the Transmission Business remunerated under E12-J2 (Restriction of Transmission Revenue: Revenue from Transmission Owner Services),

may be treated as an Excluded Service.

Part E: Authority's power to give directions

- 10. Where the Authority (having regard to the General Principle) is satisfied:
 - (k) that any service treated by the licensee as an Excluded Service should not be so treated; or
 - (l) that any service not treated by the licensee as an Excluded Service should be so treated,

it may issue to the licensee a direction to that effect.

Any directions issued under paragraph 10 shall take effect from the date of issue of such directions or such earlier date as may be specified in the directions (being not earlier than the commencement of the Relevant Year to which the information relating to excluded services last furnished pursuant to the offshore regulatory reporting - regulatory instructions and guidance directed by the Authority pursuant to Amended Standard Condition E12–D1 (Offshore Regulatory Reporting) related, unless such information, or any such information provided earlier, was incorrect or misleading in any material respect, as may be specified in the directions).

Amended Standard Condition E12-J11: The Network Innovation Competition

Introduction

1. The purpose of this condition is to establish arrangements known as the Network Innovation Competition (NIC) with respect to the funding of innovative low carbon or environmental projects carried out by the licensee.
2. This condition also makes provision for arrangements relating to the regulation, administration, and governance of the NIC.

Part A: Function of the Network Innovation Competition (NIC)

3. The function of the NIC is to enable the licensee to fund Eligible NIC Projects by means of payments received from the System Operator in accordance with the determination process described in Part B below as varied, where appropriate, by the Funding Return Mechanism described in Part C below.

Part B: The NIC Funding Mechanism

4. The NIC Funding Mechanism is the mechanism by which the licensee receives the amount of authorised NIC Funding in any Relevant Year from the System Operator, less any Funding Return as described in Part C and in accordance with the NIC Governance Document.

Part C: The Funding Return Mechanism

5. The Funding Return Mechanism relates to payments to be made by the licensee to the System Operator, in each of the following cases to such extent (if any) as may be relevant, of:
 - (a) Halted Project Revenues;
 - (b) Disallowed Expenditure;
 - (c) Returned Royalty Income; and
 - (d) Returned Project Revenues.
6. The Funding Return is the total amount, in respect of the licensee, of any amounts arising under paragraph 5.
7. Halted Project Revenues are any revenues received by the licensee from the System Operator under the NIC Funding Mechanism in respect of an Eligible NIC Project which have not yet been spent, or otherwise committed, at the time that the Authority requires that project to be halted in accordance with the applicable provisions of the NIC Governance Document or the terms of the relevant Project Direction.
8. Disallowed Expenditure is any revenue received by the licensee from the System Operator under the NIC Funding Mechanism that the Authority determines has not been spent in accordance with the applicable provisions of the NIC Governance Document or the terms of the relevant Project Direction.
9. Returned Royalty Income is revenue earned from intellectual property generated through Eligible NIC Projects undertaken by the licensee, less Directly Attributable

Costs, and that is payable to customers under the NIC Funding Mechanism, as calculated in accordance with the provisions of the NIC Governance Document.

10. For the purposes of paragraph 9, Directly Attributable Costs are costs relating to the maintenance and management of intellectual property generated through Eligible NIC Projects undertaken by the licensee that have not been otherwise remunerated under any of the arrangements by which the licensee recovers its Allowed Transmission Owner Revenue (OFTO_t) from the System Operator, Excluded Services, or the NIC Funding Mechanism.
11. Returned Project Revenues are:
 - (a) revenues received by the licensee from the System Operator under the NIC Funding Mechanism in respect of an Eligible NIC Project that the Authority determines have not been spent, and where the Project has been carried out in accordance with the applicable provisions of the NIC Governance Document and/or the terms of the relevant Project Direction; or
 - (b) revenues earned from Eligible NIC Projects by the licensee other than Returned Royalty Income, that the Authority determines are payable to customers.
12. The Authority may direct how the relevant revenues under paragraphs (a) and (b) above should be paid to customers through the Funding Return Mechanism, or where the Authority considers it to be appropriate, how they should be retained by the licensee.
13. In each Relevant Year *t*, in accordance with the appropriate provisions of the NIC Governance Document, the Authority will calculate and then, by direction given to the licensee, will specify:
 - (a) the amount of any Funding Return that the licensee must pay to the System Operator; and
 - (b) the manner in which and the timescale over which that amount is to be so paid.
14. The licensee must comply with any direction that is issued by the Authority under paragraph 13.

Part D: Determination of the NIC term

15. The NIC term is the net amount of NIC Funding less any Funding Return for the Relevant Year *t* that is to be paid to the licensee by the System Operator, or vice versa, in compliance with the determination made for that purpose in a direction issued by the Authority pursuant to the provisions of Part D of Special Condition 3I (The Network Innovation Competition) in the Transmission Licence held by the System Operator.
16. The NIC Funding to which paragraph 4 refers is the proportion (if any) of total NIC Funding raised by the System Operator from its Transmission Network Charges in accordance with the NIC Funding Mechanism that the Authority determines is to be allocated to the licensee in respect of its Eligible NIC Projects, as adjusted by the amount of any Funding Return (as to which, see Part C above).
17. In each Relevant Year *t*, as provided for by the NIC Governance Document and in accordance with the appropriate provisions of the System Operator's Transmission Licence the Authority will calculate and then, by direction given to the licensee and

other electricity Transmission Licensees, will specify, in accordance with the appropriate provisions set out in the NIC Governance Document:

- (a) the net amount of the NIC term (whether negative or positive);
- (b) how the amount of that term has been calculated, taking account of any Funding Return; and
- (c) the manner in which and the timescale over which the System Operator is required to transfer that amount to the licensee or vice versa.

Part E: The NIC Governance Document

- 18. The Authority will issue, and may from time to time revise, a document, to be known as the NIC Governance Document, for purposes connected with the regulation, governance, and administration of the NIC.
- 19. The NIC Governance Document may, without limitation, make appropriate provision about or impose requirements in respect of:
 - (a) the eligibility criteria to be applied by, and information to be provided to, the Authority in relation to the assessment and approval of proposed NIC Projects;
 - (b) the evaluation criteria against which the funding of such projects will be assessed and approved (where necessary);
 - (c) the process and procedures that will be in place for the assessment, approval, and financing of such projects' funding (where necessary);
 - (d) arrangements to ensure that relevant learning from the implementation of Eligible NIC Projects can be captured and disseminated by the licensee to other electricity Transmission Licensees and electricity Distribution Licensees;
 - (e) the nature of the reporting obligations in respect of such projects (which may include reporting in respect of the funding and the completion of such projects, as well as reporting on compliance with this condition and the provisions of the NIC Governance Document);
 - (f) arrangements relating to the treatment of intellectual property rights including Returned Royalty Income in respect of Eligible NIC Projects; and
 - (g) any other matters relating to the regulation, governance, or administration of the NIC.
- 20. Where provisions of the NIC Governance Document require the compliance of the licensee, the licensee must comply with those provisions as if the NIC Governance Document were part of this condition.

Part F: Procedure for issuing and revising the NIC Governance Document

- 21. Before issuing the NIC Governance Document under this condition, the Authority, by Notice given to the licensee and other electricity Transmission Licensees and electricity Distribution Licensees with a condition of similar effect to this condition in their license, must:

- (a) state that it proposes to issue the NIC Governance Document, and specify the date on which it proposes that the document should take effect;
 - (b) set out the text of the NIC Governance Document and the Authority's reasons for proposing to issue it; and
 - (c) specify the date (which must not be less than a period of 28 days from the date of the notice) within which representations with respect to the proposed NIC Governance Document may be made.
22. The Authority will consider any representations that are duly made.
23. The requirements of paragraphs 21 and 22 may be satisfied by action taken before, as well as by action taken after, the commencement of this condition.
24. In paragraph 21, "issuing the NIC Governance Document" includes issuing any revision of the document, and the procedure provided for under that paragraph will apply to any such revision.

Amended Standard Condition E12-J12: Sulphur Hexafluoride Reporting Requirements

Part A: Introduction

1. This purpose of this condition is to require the licensee to provide annual submissions to the Authority about its sulphur hexafluoride emissions.

Part B: Licensee's obligations

2. The licensee must, in accordance with Amended Standard Condition E12-D1 (Offshore Regulatory Reporting), prepare and submit to the Authority details of the sulphur hexafluoride emissions arising directly or indirectly from the operations and activities of the licensee's Transmission Business during the Relevant Year.
3. Any Offshore Transmission Owner Regulatory Instructions and Guidance issued under Amended Standard Condition E12-D1 (Offshore Regulatory Reporting) may, in particular, include provision about or impose requirements in respect of:
 - (a) the form in which the licensee is to prepare and present its sulphur hexafluoride emissions information;
 - (b) the inclusion within the submission of a standard template for the presentation of information in a common format; and
 - (c) the matters that are to be explained by the licensee in a commentary to accompany the submission, including, in particular the data sources and processes relied upon by the licensee for the purposes of recording or estimating sulphur hexafluoride emissions.
4. The provisions of the Offshore Transmission Owner Regulatory Instructions and Guidance must not exceed what is reasonably required to achieve the purpose of this condition.

Part C: Availability of the sulphur hexafluoride emissions information

5. At the same time in each Relevant Year as it submits its sulphur hexafluoride emissions to the Authority, the licensee must also:
 - (a) publish that information in such manner as the licensee believes will ensure adequate publicity for it (for example by making it readily accessible from the licensee's website); and
 - (b) give or send a copy of that information to any person who requests one.
6. The licensee may charge for any information given or sent pursuant to paragraph 5(b). The amount of the charge must reflect the licensee's reasonable costs of providing such a statement and must not exceed the maximum amount specified in any directions issued by the Authority for the purposes of this condition.

Condition E13: System Operator – Transmission Owner Code

Insert text below after paragraph 4

5. Where the Authority issues a direction under this paragraph, any reference to a special condition in the STC or the STC Framework Agreement shall have such effect in relation to this licence as if "Amended Standard Condition" were construed as "Special Condition" as set out below:

Amended Standard Condition reference	STC reference
Amended Standard Condition E12–A1: Definitions and Interpretation	Special Condition A1: Definitions and Interpretation
Amended Standard Condition E12–A2: Market Rate Revenue Adjustment	Special Condition A2: Market Rate Revenue Adjustment
Amended Standard Condition E12–A3: Post Tender Revenue Adjustment	Special Condition A3: Post Tender Revenue Adjustment
Amended Standard Condition E12–B1: Transmission System Area	Special Condition B1: Transmission System Area
Amended Standard Condition E12–B2: Activities Restrictions	Special Condition B2: Activities Restrictions
Amended Standard Condition E12–C1: Conduct of the Transmission Business	Special Condition C1: Conduct of the Transmission Business
Amended Standard Condition E12–C2: Separation and Independence of the Transmission Business	Special Condition C2: Separation and Independence of the Transmission Business
Amended Standard Condition E12–C3: Restriction on use of certain information	Special Condition C3: Restriction on use of certain information
Amended Standard Condition E12–C4: Appointment of Compliance Officer	Special Condition C4: Appointment of Compliance Officer
Amended Standard Condition E12–D1: Offshore Regulatory Reporting	Special Condition D1: Offshore Regulatory Reporting
Amended Standard Condition E12–D2: Equity Transaction Reporting Requirement	Special Condition D2: Equity Transaction Reporting Requirement
Amended Standard Condition E12–J1: Not Used	Special Condition J1: Not Used
Amended Standard Condition E12–J2: Restriction of Transmission Revenue: Revenue from Transmission Owner Services	Special Condition J2: Restriction of Transmission Revenue: Revenue from Transmission Owner Services
Amended Standard Condition E12–J3: Restriction of Transmission Revenue: Allowed Pass-through Items	Special Condition J3: Restriction of Transmission Revenue: Allowed Pass-through Items
Amended Standard Condition E12–J4: Restriction of Transmission Revenue: Annual Revenue Adjustments	Special Condition J4: Restriction of Transmission Revenue: Annual Revenue Adjustments

Amended Standard Condition E12–J5: Restriction of Transmission Revenue: Adjustments	Special Condition J5: Restriction of Transmission Revenue: Adjustments
Amended Standard Condition E12–J6: Provision of Information to the System Operator	Special Condition J6: Provision of Information to the System Operator
Amended Standard Condition E12–J7: Duration of the Revenue Restriction Provisions	Special Condition J7: Duration of the Revenue Restriction Provisions
Amended Standard Condition E12–J8: Allowances in respect of Security Costs	Special Condition J8: Allowances in respect of Security Costs
Amended Standard Condition E12– J9: Basis of Transmission Owner Charges	Special Condition J9: Basis of Transmission Owner Charges
Amended Standard Condition E12–J10: Excluded Services	Special Condition J10: Excluded Services
Amended Standard Condition E12–J11: The Network Innovation Competition	Special Condition J11: The Network Innovation Competition
Amended Standard Condition E12–J12: Sulphur Hexafluoride Reporting Requirements	Special Condition E12–J12: Sulphur Hexafluoride Reporting Requirements

6. For the purposes of Section E of this licence:

"STC"	means the System Operator - Transmission Owner Code, being a document which sets out terms as between STC parties whereby the National Electricity Transmission System and each STC party's transmission system forming part thereof is to be planned, developed or operated and Transmission Services are to be provided together with any associated arrangements.
-------	--

PART IV. SPECIAL CONDITIONS

There are no Special Conditions.

Schedule 1: Specified Area

Great Britain, an area of waters in or adjacent to Great Britain which is between the mean low water mark and the seaward limits of the territorial sea, and an area of waters within an area designated under section 1(7) of the Continental Shelf Act 1964 and in any Renewable Energy Zone.

where:

Renewable Energy Zone has the meaning given by section 84(4) of the Energy Act 2004.

Schedule 2: Revocation

1. The Authority may at any time revoke the licence by giving not less than 30 days' notice (24 hours' notice, in the case of a revocation under sub-paragraph 1(f)) in writing to the licensee:
 - (a) if the licensee agrees in writing with the Authority that the licence should be revoked;
 - (b) if any amount payable under Standard Condition A4 (Payments by Licensee to the Authority) is unpaid 30 days after it has become due and remains unpaid for a period of 14 days after the Authority has given the licensee notice that the payment is overdue - provided that no such notice shall be given earlier than the sixteenth after the day on which the amount payable became due;
 - (c) if the licensee fails:
 - (i) to comply with a final order (within the meaning of section 25 of the Act) or with a provisional order (within the meaning of that section) which has been confirmed under that section and (in either case) such failure is not rectified to the satisfaction of the Authority within three months after the Authority has given notice of such failure to the licensee - provided that no such notice shall be given by the Authority before the expiration of the period within which an application under section 27 of the Act could be made questioning the validity of the final or provisional order or before the proceedings relating to any such application are finally determined; or
 - (ii) to pay any financial penalty (within the meaning of section 27A of the Act) by the due date for such payment and such payment is not made to the Authority within three months after the Authority has given notice of such failure to the licensee - provided that no such notice shall be given by the Authority before the expiration of the period within which an application under section 27E of the Act could be made questioning the validity or effect of the financial penalty or before the proceedings relating to any such application are finally determined;
 - (d) if the licensee fails to comply with:
 - (i) an order made by the court under section 34 of the Competition Act 1998;
 - (ii) an order made by the Authority under sections 158 or 160 of the Enterprise Act 2002;
 - (iii) an order made by the Competition Commission under sections 76, 81, 83, 84 and 161 of the Enterprise Act 2002;
 - (iv) an order made by the Secretary of State under sections 66, 147, 160 or 161 of the Enterprise Act 2002;
 - (e) if the licensee:
 - (i) has ceased to carry on the Transmission Business;

- (ii) has not commenced carrying on the Transmission Business within 3 years of the date on which the licence comes into force;
 - (iii) has not been certified by the Authority in accordance with section 10D of the Act as complying with the requirement of the section 10A of the Act; or
 - (iv) has not continued to be certified by the Authority in accordance with section 10I and section 10L of the Act as complying with the requirement of section 10A of the Act.
- (f) if the licensee:
- (i) is unable to pay its debts (within the meaning of section 123(1) or (2) of the Insolvency Act 1986, but subject to paragraphs 2 and 3 of this schedule) or has any voluntary arrangement proposed in relation to it under section 1 of that Act or enters into any scheme of arrangement (other than for the purpose of reconstruction or amalgamation upon terms and within such period as may previously have been approved in writing by the Authority);
 - (ii) has a receiver (which expression shall include an administrative receiver within the meaning of section 251 of the Insolvency Act 1986) of the whole or any material part of its assets or undertaking appointed;
 - (iii) has an administration order under section 8 of the Insolvency Act 1989 made in relation to it;
 - (iv) passes any resolution for winding-up other than a resolution previously approved in writing by the Authority; or
 - (v) becomes subject to an order for winding-up by a court of competent jurisdiction.
2. For the purposes of sub-paragraph 1(f)(i), section 123(1)(a) of the Insolvency Act 1989 shall have effect as if for "£750" there was substituted "£250,000" or such higher figure as the Authority may from time to time determine by notice in writing to the licensee.
 3. The licensee shall not be deemed to be unable to pay its debts for the purposes of sub-paragraph 1(f)(i) if any such demand as is mentioned in section 123(1)(a) of the Insolvency Act 1989 is being contested in good faith by the licensee with recourse to all appropriate measures and procedures or if any such demand is satisfied before the expiration of such period as may be stated in any notice given by the Authority under paragraph 1.
 4. The Authority may at any time revoke the licence by giving no less than 7 days' notice in writing to the licensee where the Authority is satisfied that there has been a material misstatement (of fact) by, or on behalf of the licensee, in making its application for the licence.

